



## touchMATRIX Indicator WY050100

Pulse counter, tachometer and speed indicator with touchscreen and graphic display

### Product features:

- Multifunctional unit with several operating modes, e. g. speed or position indicator, counter, flow time indicator, timer, stopwatch or process indicator
- Universal inputs (HTL) for encoders / sensors with NPN / PNP / NAMUR characteristic
- Bright and high-contrast display with event controlled color variations
- Emulation of a 7-segment display inclusively icons and units
- Intuitive and easy parameterization by plain text and touchscreen
- 24V auxiliary output for encoder supply
- Input frequencies up to 250kHz
- Linearization with 24 interpolation points
- Numerous features, e. g. scaling, filtering, start-up suppression
- 96 x 48 mm (3.78 x 1.89 inch) norm panel housing and IP65 protection

### Available options:

**WY050100:** Basic unit with HTL inputs (A, B), 3 control inputs, 16 bit analog output, 4 control outputs, serial RS232 interface

<b>Version:</b>	<b>Description</b>
Jul 2017	First Version
December 2017	Software customization Expansion of the sale unit / fixes
Mai 2020	Expansion of the serial interfaces - Modbus
August 2020	Extension of chapter 1.4 "EMC Guidelines"

# Table of Contents

<b>1. Safety Instructions and Responsibility .....</b>	<b>5</b>
1.1. General Safety Instructions .....	5
1.2. Use according to the intended purpose .....	5
1.3. Installation .....	6
1.4. EMC-Guidelines.....	7
1.5. Cleaning, Maintenance and Service Notes .....	7
<b>2. Introduction .....</b>	<b>8</b>
2.1. Operation mode .....	8
2.2. Function diagram.....	9
<b>3. Electrical Connections .....</b>	<b>10</b>
3.1. DC Power Supply.....	10
3.2. Auxiliary Voltage Output .....	10
3.3. Incremental Input A, B.....	12
3.4. Control Inputs .....	14
3.5. Analog Output.....	14
3.6. Serial interface.....	16
3.7. Control-Output .....	16
<b>4. Display and touch screen.....</b>	<b>17</b>
4.1. Screen structure for parametrization .....	17
4.2. Screen structure in operation.....	19
4.3. Error messages .....	20
<b>5. Parameter / Overview-Menu Structure .....</b>	<b>23</b>
5.1. General Menu .....	20
5.2. Mode Speed.....	29
5.3. Mode Process Time .....	31
5.4. Mode Timer .....	35
5.5. Mode Counter.....	38
5.6. Mode Velocity.....	40
5.7. Preselection Values.....	42
5.8. Preselection 1 Menu.....	43
5.9. Preselection 2 Menu.....	47
5.10. Preselection 3 Menu.....	39
5.11. Preselection 4 Menu.....	40
5.12. Serial Menu.....	52
5.13. Analog Menu.....	55
5.14. Command Menu .....	57
5.15. Display Menu .....	59
5.16. Linearization Menu .....	49

<b>6. Appendix.....</b>	<b>50</b>
6.1. Data readout via serial interface .....	50
6.2. Modbus RTU Interface.....	64
6.2.1. Parameter setting.....	51
6.2.2. Modbus Communication.....	52
6.2.3. Diagnostics .....	54
6.3. Parameter / serial codes.....	55
6.4. Linearization .....	60
6.5. Dimensions .....	77
6.6. Technical specifications .....	79

# 1. Safety Instructions and Responsibility

## 1.1. General Safety Instructions

This operation manual is a significant component of the unit and includes important rules and hints about the installation, function and usage. Non-observance can result in damage and/or impairment of the functions to the unit or the machine or even in injury to persons using the equipment!

**Please read the following instructions carefully before operating the device and observe all safety and warning instructions! Keep the manual for later use.**

A pertinent qualification of the respective staff is a fundamental requirement in order to use these manual. The unit must be installed, connected and put into operation by a qualified electrician.

**Liability exclusion:** The manufacturer is not liable for personal injury and/or damage to property and for consequential damage, due to incorrect handling, installation and operation. Further claims, due to errors in the operation manual as well as misinterpretations are excluded from liability.

In addition the manufacturer reserves the right to modify the hardware, software or operation manual at any time and without prior notice. Therefore, there might be minor differences between the unit and the descriptions in operation manual.

The raiser respectively positioner is exclusively responsible for the safety of the system and equipment where the unit will be integrated.

During installation or maintenance all general and also all country- and application-specific safety rules and standards must be observed.

If the device is used in processes, where a failure or faulty operation could damage the system or injure persons, appropriate precautions to avoid such consequences must be taken.

## 1.2. Use according to the intended purpose

The unit is intended exclusively for use in industrial machines, constructions and systems. Non-conforming usage does not correspond to the provisions and lies within the sole responsibility of the user. The manufacturer is not liable for damages which have arisen through unsuitable and improper use.

Please note that device may only be installed in proper form and used in a technically perfect condition (in accordance to the Technical Specifications). The device is not suitable for operation in explosion-proof areas or areas which are excluded by the EN 61010-1 standard.

### 1.3. Installation

The device is only allowed to be installed and operated within the permissible temperature range. Please ensure an adequate ventilation and avoid all direct contact between the device and hot or aggressive gases and liquids.

Before installation or maintenance, the unit must be disconnected from all voltage-sources. Further it must be ensured that no danger can arise by touching the disconnected voltage-sources.

Devices which are supplied by AC-voltages must be connected exclusively by switches, respectively circuit-breakers with the low voltage network. The switch or circuit-breaker must be placed as near as possible to the device and further indicated as separator.

Incoming as well as outgoing wires and wires for extra low voltages (ELV) must be separated from dangerous electrical cables (SELV circuits) by using a double resp. increased isolation.

All selected wires and isolations must be conform to the provided voltage- and temperature-ranges. Further all country- and application-specific standards, which are relevant for structure, form and quality of the wires, must be ensured. Indications about the permissible wire cross-sections for wiring are described in the Technical Specifications.

Before first start-up it must be ensured that all connections and wires are firmly seated and secured in the screw terminals. All (inclusively unused) terminals must be fastened by turning the relevant screws clockwise up to the stop.

Overvoltages at the connections must be limited to values in accordance to the overvoltage category II.

## 1.4. EMC Guidelines

All devices of this series are designed to provide high protection against electromagnetic interference. Nevertheless you must minimize the influence of electromagnetic noise to the device and all connected cables.

Therefore the following measures are mandatory for a successful installation and operation:

- **Use shielded cables for all signal and control input and output lines.**
- **Cables for digital controls (digital I/O, relay outputs) must not exceed a length of 30m and are allowed for in building operation only**
- Use shield connection clamps to connect the cable shields properly to earth
- The wiring of the common ground lines must be star-shaped and common ground must be connected to earth at only one single point
- The device should be mounted in a metal enclosure with sufficient distance to sources of electromagnetic noise.
- Run signal and control cables apart from power lines and other cables emitting electromagnetic noise.

## 1.5. Cleaning, Maintenance and Service Notes

To clean the front of the unit please use only a slightly damp (not wet!), soft cloth. For the rear no cleaning is necessary. For an unscheduled, individual cleaning of the rear the maintenance staff or assembler is self-responsible.

During normal operation no maintenance is necessary. In case of unexpected problems, failures or malfunctions the device must be shipped for back to the manufacturer for checking, adjustment and reparation (if necessary). Unauthorized opening and repairing can have negative effects or failures to the protection-measures of the unit.

## 2. Introduction

This series of display unit is suitable for HTL impulse signals and panel mounting. It is very versatile in use, due to the intuitive handling and the extensive range of functions and options.

### 2.1. Operation mode

All functions can be configured in the parameter menu.

The device can be set to one of the following operation modes:

- SPEED (only Input A or Input B are used, depending on the parameter setting)
  - Tachometers / speed indicator
  - Measurement of frequency / RMP indicator
  - Monitoring functions for speed and standstill
- PROCESS TIME (only input A is used)
  - Processing time indicator (reciprocal speed)
  - Baking time indicator
  - Flow time indicator
- TIMER (only Input A or Input B are used, depending on the parameter setting)
  - Operation as stopwatch (start- / stop function can be freely parameterized)
  - Counter for operation hours
  - Period measurement
  - Total time measurement
- COUNTER (input A and input B are used)
  - Pulse counter / sum or differential counter
  - Up- or down counter
  - Position indicator
  - Quadrature counter
  - Batch counter / total counter
- VELOCITY (Input A operates as a start input and input B operates as a stop input)
  - Runtime measurement as speed indicator.



## 2.2. Function diagram

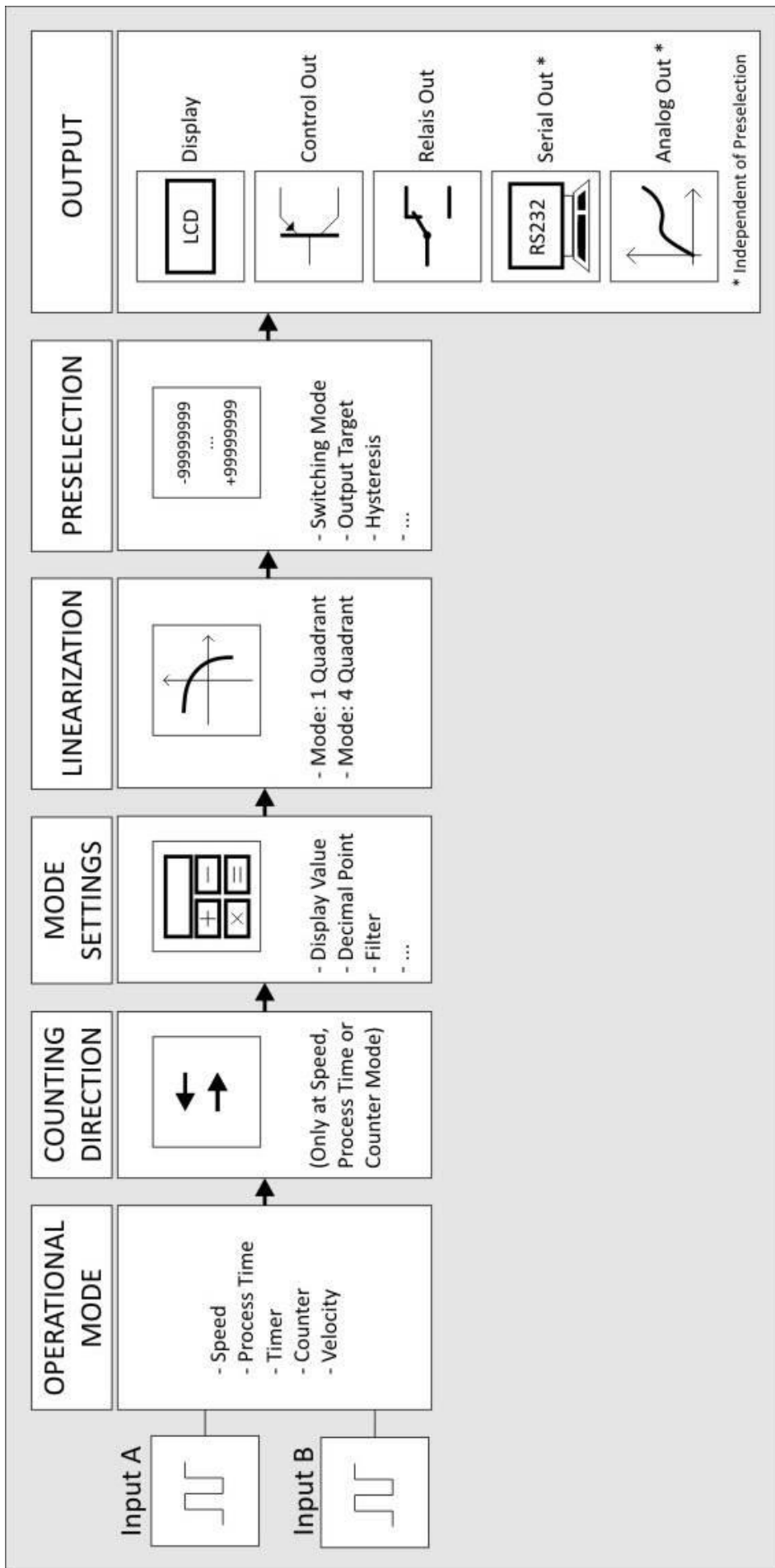

### 3. Electrical Connections

The terminal screws should be tightened with a slotted screwdriver (blade width 2mm).

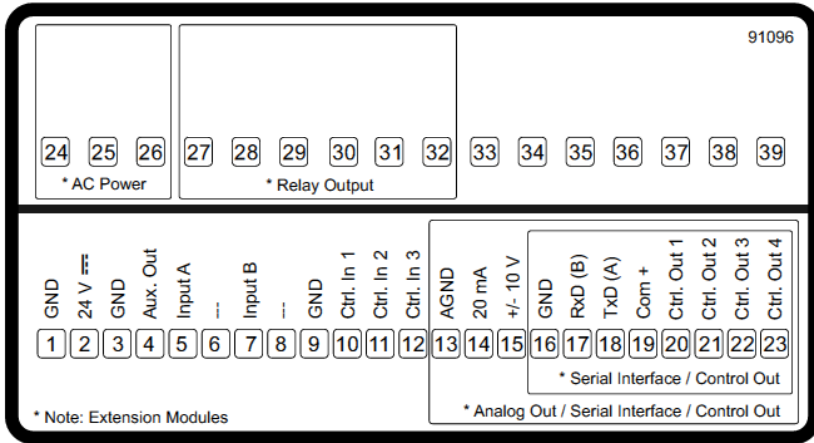

#### 3.1. DC Power Supply

The unit accepts DC supply from 18 to 30 V at the terminals 1 and 2. The power consumption depends on the level of the supply voltage with approx. 100 mA and the additional current required at the Auxiliary Voltage Output.

All GND terminals are internally interconnected.

#### 3.2. Auxiliary Voltage Output

Terminal 3 and 4 provide an auxiliary output for supply of sensors and encoders. The encoder voltage is approx. 1 V lower than the power supply voltage at terminal 1 and 2 and should be loaded with max. 250 mA.

### 3.3. Incremental Input A, B

The unit provides two inputs at terminal 5 and 7 for HTL signals.

The characteristics of the incremental input (PNP, NPN, Namur or Tri-State) can be set in the GENERAL MENU.

#### Wiring of the incremental inputs:

##### PNP

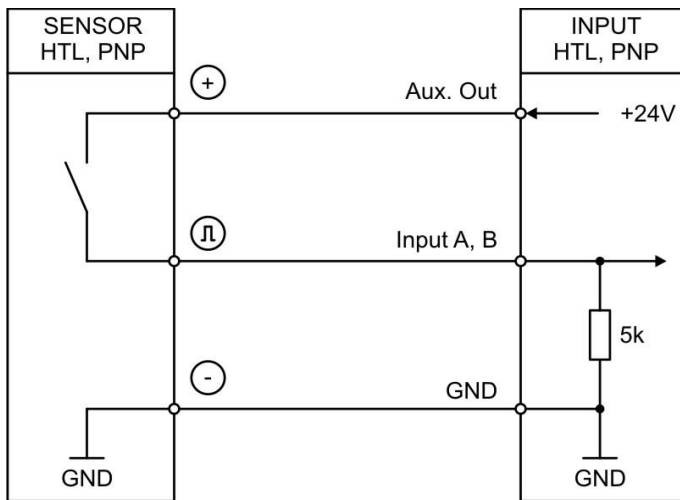

##### NPN

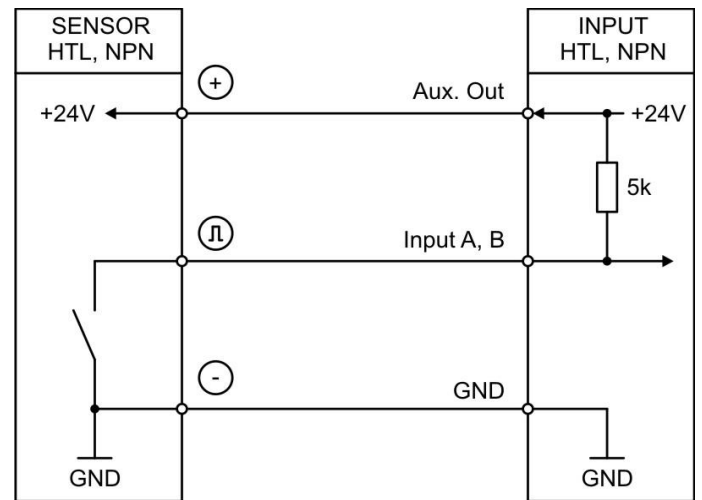

##### Namur

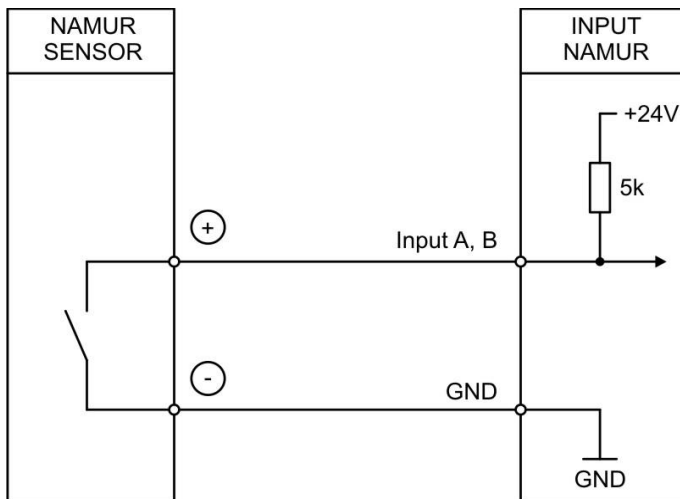

##### Tri-State

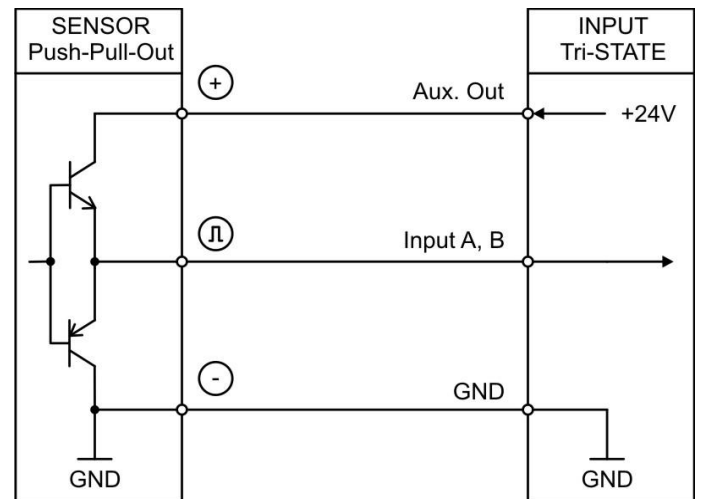

Unconnected PNP inputs are always “LOW” and unconnected NPN inputs are always “HIGH”. All inputs are designed to receive impulses from electrical impulse sources.

#### Notice for mechanical switching contacts:

When exceptionally mechanical contacts are used, please connect an external capacitor between GND (-) and the corresponding input (+). A capacity of 10 µF will reduce the input frequency to

20 Hz and miscounting due to contact bouncing will be eliminated.



### 3.4. Control Inputs

The three control inputs at terminal 10, 11 and 12 have HTL PNP characteristics. In the COMMAND MENU the programmable functions for the control inputs can be assigned. Available functions are: reset the display value, display switching, locking the touch screen or release the lock function of the control or relay outputs.

Wiring of the control inputs:

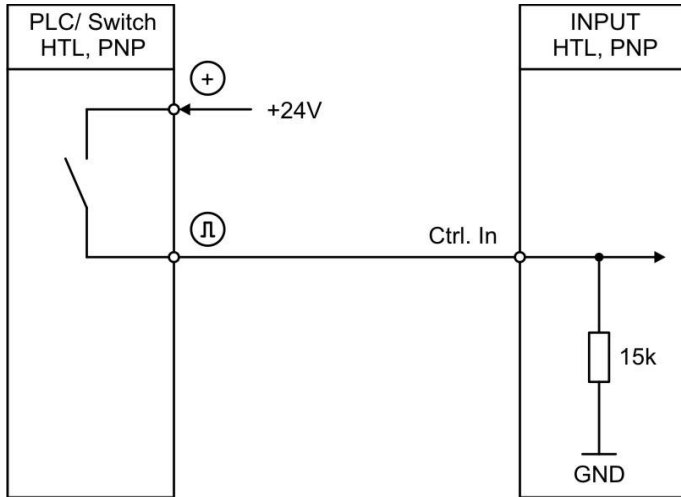

Unconnected control inputs are always “LOW”. All inputs are designed to receive impulses from an electronic impulse source.

**Notice for mechanical switching contacts:**

When exceptionally mechanical contacts are used, please connect an external capacitor between GND (-) and the corresponding input (+). A capacity of 10 µF will reduce the input frequency to 20 Hz and miscounting due to contact bouncing will be eliminated.

### 3.5. Analog Output

A 16 bit analog output is available at terminal 13 and 14 / 15 This output can be configured and scaled in the ANALOG MENU.

The following configuration is possible:

- Voltage output: -10 ... +10 V
- Current output: 0 ... 20 mA
- Current output: 4 ... 20 mA

The analog output is proportional to the reference source and is referenced to potential AGND.

AGND and GND are internally interconnected.



**Important:**

**A parallel operation with voltage and current output at the analog output is not allowed.**

### 3.6. Serial interface

A serial interface (RS232) is available at terminal 16, 17 und 18. This interface can be configured in the SERIAL MENU.

The serial interface RS232 can be used:

- for easy setup and commissioning of the units
- to modify settings and parameters during operation
- to read out internal states and actual measuring values by PC or PLC

The following drawing shows the connection to a PC by using a standard Sub-D-9 connector:

Connection of the RS232 interface:

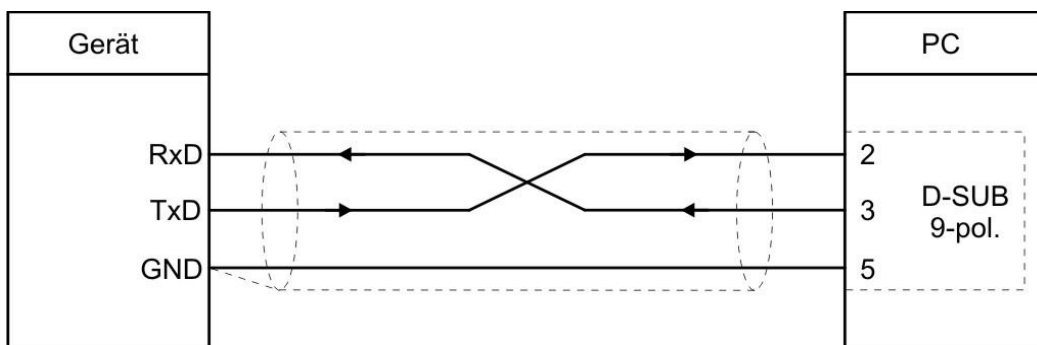

### 3.7. Control-Output

Four control outputs are available at terminal 20, 21, 22 and 23.

Switching conditions can be set in the PRESELECTION MENU. The output Ctrl. Out1 – 4 are fast PNP outputs with a switching capability of 5 – 30 Volt / 200 mA per channel. The switching states is displayed (display with unit and status bar) as C1 ... C4.

The switching voltage of the outputs must be applied to input terminal 19 (COM+).

In case of switching inductive loads it is advisable to use external filtering of the coils.

Wiring of the control-outputs:



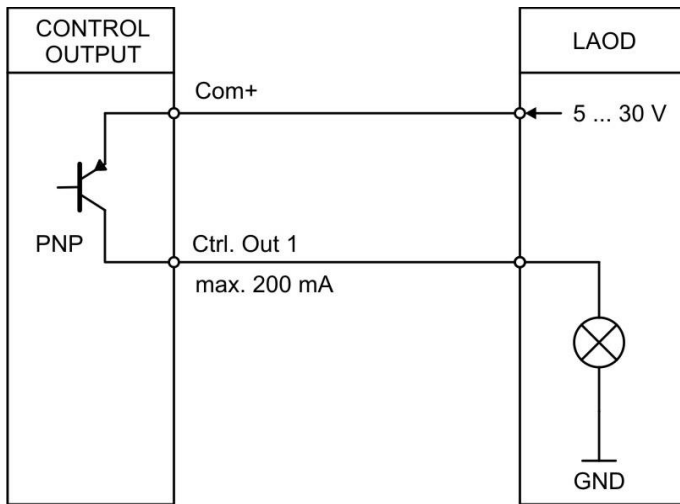

## 4. Display and touch screen

### 4.1. Screen structure for parametrization

The parameter menus and the parameters are described in chapter 5.

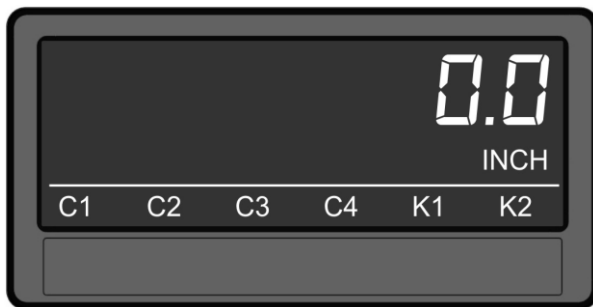

Start setup procedure:

To edit the parameters, press the touchscreen for 3 seconds.



Menu selection:

Select the parameter menu via arrow buttons and confirm with "OK".

The menu selection can be terminated with „C“.



Parameter selection:

Select the parameter via arrow buttons and confirm with „OK“.

The parameter selection can be terminated with „C“.

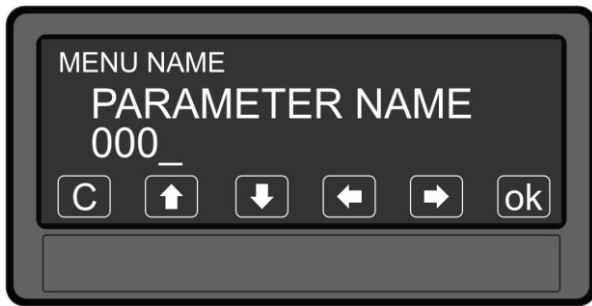

### Parameter editing:

Edit the parameter via arrow button up and down, shift cursor via left and right and save with „OK“.

The parameter editing can be terminated with „C“.

**Parameter changes becomes active only after closing the menu selection.**

## 4.2. Screen structure in operation

The following screens are available during operation. Depending on the device version and the selected operation mode, not all displays will be shown.



### Display with unit and status bar

To switch to the next display, press the touch screen.



### Display counter and batch- / total counter or timer and total timer

To switch to the next display, press the top of the screen.

This is only possible in operation mode COUNTER A+B, A-B or BATCH / TOTAL MODE is active or in operation mode TIMER – TOTAL TIME MODE is active.



### Two-line display with units

To switch to the next display, press the top of the screen.

This is only possible in operation mode COUNTER A+B, A-B or BATCH / TOTAL MODE is active or in operation mode TIMER – TOTAL TIME MODE is active.



### Large Display (4 digits)

To switch to the next display, press the top of the screen.

This is only possible with activated parameter „LARGE DISPLAY“.



Continuation „Screen structure in operation“:



Display with command keys

To switch to the next display, press the top of the screen.

This is only possible in operation mode TIMER or COUNTER.

Display for quick start for enter preselection values (PRESELECTION VALUES)

To switch to the next display, press the top of the screen or the “skip” button.

Display with minimum and maximum value

To switch to the next display, press the top of the screen or the “skip” button.

**4.3. Error messages**

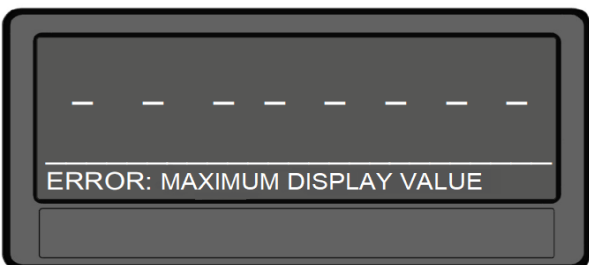

ERROR: MAXIMUM DISPLAY VALUE

The display value of the single-line display is greater than + 99 999 999

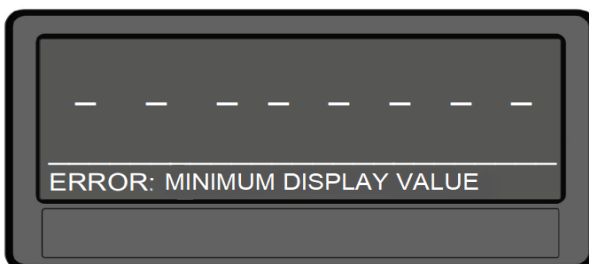

ERROR: MINIMUM DISPLAY VALUE

The display value of the single-line display is less than - 99 999 999

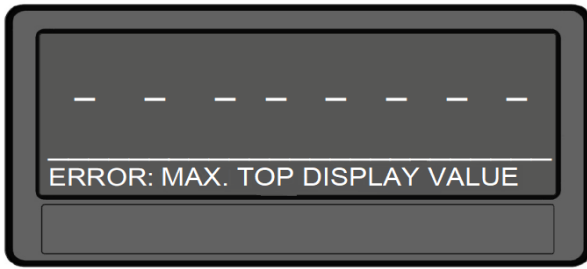

ERROR: MAX. TOP DISPLAY VALUE

Top display value of the two-line display is greater than + 99 999 999

Continuation „Error messages“:

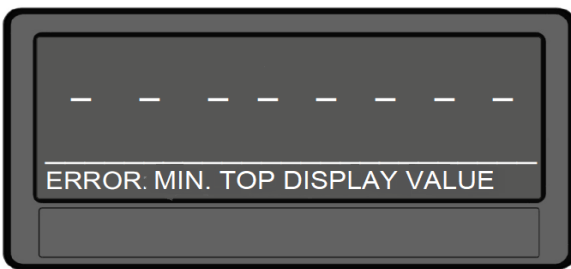

ERROR: MIN. TOP DISPLAY VALUE

Top display value of the two-line display is less than - 99 999 999

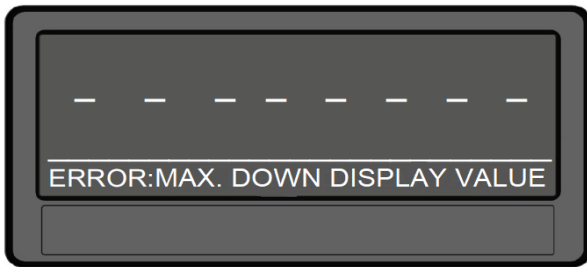

ERROR: MAX. DOWN DISPLAY VALUE

Down display value of the two-line display is greater than + 99 999 999

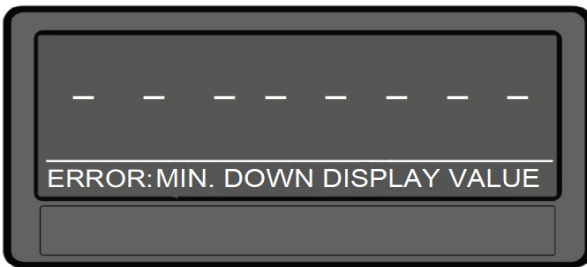

ERROR: MIN. DOWN DISPLAY VALUE

Down display value of the two-line display is less than - 99 999 999

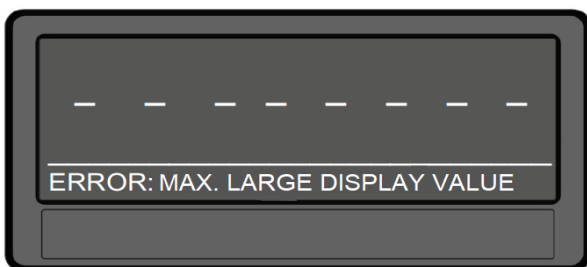

ERROR: MAX. LARGE DISPLAY VALUE

The display value of the large display is greater than + 9999

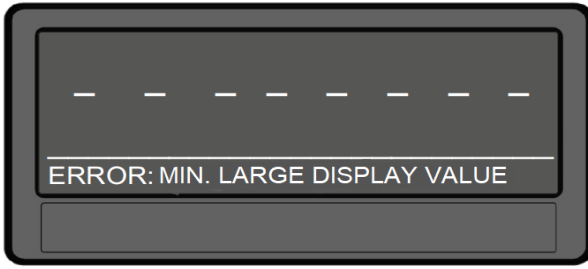

ERROR: MIN. LARGE DISPLAY VALUE

The display value of the large display is less than – 999



The error messages described are automatically reset as soon as the corresponding display value is within the representable range.

## 5. Parameter / Overview-Menu Structure

This section provides an overview of the menus and their parameters. The menu names are printed bold and the associated parameters are listed under the menu name. Depending on the device version and the selected operation mode, only the necessary menus / parameters are shown.

Menu / Parameter	Menu / Parameter
<b>GENERAL MENU</b>	<b>MODE SPEED</b>
OPERATIONAL MODE	DISPLAY VALUE
ENCODER PROPERTIES	BASE FREQUENCY
ENCODER SUPPLY	DECIMAL POINT
COUNTING DIRECTION	SAMPLING TIME
SCALE UNITS	WAIT TIME
SCALE UNITS (BATCH)	STANDSTILL TIME
LINEARIZATION MODE	AVERAGE FILTER
PIN PRESELECTION	FOR/REV DETECTION
PIN PARAMETER	<b>MODE PROCESS TIME</b>
BACK UP MEMORY	DISPLAY FORMAT
FACTORY SETTINGS	DISPLAY VALUE
	BASE FREQUENCY
	SAMPLING TIME
	WAIT TIME
	STANDSTILL TIME
	AVERAGE FILTER
	<b>MODE TIMER</b>
	TIME BASE
	START / STOP
	AUTO RESET
	LATCH FUNCTION
	SET VALUE
	INC / DEC MODE
	TOTAL TIME MODE
	TOTAL TIME SET VALUE
	<b>MODE COUNTER</b>
	COUNT MODE
	FACTOR
	SET VALUE
	DECIMALPOINT
	BATCH / TOTAL MODE
	BATCH / TOTAL SET VALUE
	ROUND LOOP VALUE
	<b>MODE VELOCITY</b>
	START / STOP
	DISPLAY VALUE
	BASE TIME

DECIMALPOINT
WAIT TIME
STANDSTILL TIME

Menu / Parameter
<b>PRESELECTION VALUES</b>
PRESELECTION 1
PRESELECTION 2
PRESELECTION 3
PRESELECTION 4
<b>PRESELECTION 1 MENU</b>
SOURCE 1
MODE 1
HYSTERESIS 1
PULSE TIME 1
OUTPUT TARGET 1
OUTPUT POLARITY 1
OUTPUT LOCK 1
START UP DELAY 1
EVENT COLOR 1
<b>PRESELECTION 2 MENU</b>
SOURCE 2
MODE 2
HYSTERESIS 2
PULSE TIME 2
OUTPUT TARGET 2
OUTPUT POLARITY 2
OUTPUT LOCK 2
START UP DELAY 2
EVENT COLOR 2
<b>PRESELECTION 3 MENU</b>
SOURCE 3
MODE 3
HYSTERESIS 3
PULSE TIME 3
OUTPUT TARGET 3
OUTPUT POLARITY 3
OUTPUT LOCK 3
START UP DELAY 3
EVENT COLOR 3
<b>PRESELECTION 4 MENU</b>
SOURCE 4
MODE 4
HYSTERESIS 4
PULSE TIME 4
OUTPUT TARGET 4

Menu / Parameter
<b>SERIAL MENU</b>
UNIT NUMBER
SERIAL BAUD RATE
SERIAL FORMAT
SERIAL INIT
SERIAL PROTOCOL
SERIAL TIMER
SERIAL VALUE
MODBUS
<b>ANALOG MENU</b>
ANALOG SOURCE
ANALOG FORMAT
ANALOG START
ANALOG END
ANALOG GAIN
ANALOG OFFSET
<b>COMMAND MENU</b>
INPUT 1 ACTION
INPUT 1 CONFIG
INPUT 2 ACTION
INPUT 2 CONFIG
INPUT 3 ACTION
INPUT 3 CONFIG
<b>DISPLAY MENU</b>
SOURCE DUAL TOP
SOURCE DUAL TOWN
COLOR
BRIGHTNESS
CONTRAST
SCREEN SAVER
UP-DATE-TIME
FONT
START DISPLAY
LARGE DISPLAY
<b>LINEARISATION MENU</b>
P1(X)
P1(Y)
P2(X)
P2(Y)
...
...



OUTPUT POLARITY 4  
 OUTPUT LOCK 4  
 START UP DELAY 4  
 EVENT COLOR 4

P23(X)  
 P23(Y)  
 P24(X)  
 P24(Y)

## 5.1. General Menu

### OPERATIONAL MODE

This parameter specifies the selected measuring function.

<b>0</b>	<b>SPEED</b>	Speed indicator (RPM), tachometer or frequency counter
<b>1</b>	<b>PROCESS TIME</b>	Operation as baking time or processing time indicator (reciprocal speed)
<b>2</b>	<b>TIMER</b>	Operation as stopwatch
<b>3</b>	<b>COUNTER</b>	Operation as position indicator, event-, sum-, differential- or up-down counter
<b>4</b>	<b>VELOCITY</b>	Runtime measurement as speed indicator

### ENCODER PROPERTIES (for DX350)

This parameter determines the characteristics of the pulse input for DX350.

<b>0</b>	<b>PNP</b>	PNP (switch to +)
<b>1</b>	<b>NPN</b>	NPN (switch to -)
<b>2</b>	<b>NAMUR</b>	Connect sensor (-) to GND and sensor (+) to input (A or B)
<b>3</b>	<b>TRI-STATE</b>	Tri-State for push-pull encoders/ sensors

### ENCODER SUPPLY (only for DX355 available)

This parameter defines the voltage of the auxiliary supply output (Aux-Out).

<b>0</b>	<b>24VDC SUPPLY</b>	24 VDC encoder supply
<b>1</b>	<b>5VDC SUPPLY</b>	5 VDC encoder supply

### COUNTING DIRECTION

This parameter determines the direction of counting. (Only in mode COUNTER)

<b>0</b>	<b>FORWARD</b>	forward
<b>1</b>	<b>REVERSE</b>	reverse

Continuation „General Menu“:

**SCALE UNITS**

This parameter defines the required engineering unit. This parameter does not affect the calculation of the display value. The number of decimal places must be defined with the parameter DECIMAL POINT. For the two-line display the unit set as well as the decimal point of the display value are automatically taken for the total counter or total timer, too. The unit for the batch counter can separately be selected by using SCALE UNITS (BATCH).

0	Hz	Default																																																
1	kHz																																																	
2	m/s																																																	
3	m/min																																																	
4	km/h																																																	
5	mph																																																	
6	1/min																																																	
7	RPM																																																	
8	1/sec																																																	
9	RPS																																																	
10	Stk/h																																																	
11	pcs/h																																																	
12	mm																																																	
13	m																																																	
14	inch																																																	
15	feet																																																	
16	Stueck																																																	
17	pcs																																																	
18	sec																																																	
19	min																																																	
20	Min:Sec																																																	
21	H:M:S																																																	
22	Min:Sec:00																																																	
23	l/min																																																	
24	gal/min																																																	
25	ml/min																																																	
26	gr/min																																																	
27	inch/min																																																	
28	H:M																																																	
29	<b>Edit Unit</b>	<p>A customized unit with up to 16 digits can be edited using this parameter. Pressing the "OK" button opens the Edit Unit Menu. A unit can be created using the arrow keys. (by pressing and holding the arrow keys the characters scroll fast). The "OK" button saves the Edit Unit Menu. The "C" button closes the Edit Unit Menu.</p> <table border="1"> <tr> <td></td> <td>!</td> <td>"</td> <td>#</td> <td>\$</td> <td>%</td> <td>&amp;</td> <td>'</td> <td>(</td> <td>)</td> <td>*</td> <td>+</td> <td>,</td> <td>-</td> <td>.</td> <td>/</td> </tr> <tr> <td>0</td> <td>1</td> <td>2</td> <td>3</td> <td>4</td> <td>5</td> <td>6</td> <td>7</td> <td>8</td> <td>9</td> <td>:</td> <td>;</td> <td>&lt;</td> <td>=</td> <td>&gt;</td> <td>?</td> </tr> <tr> <td>@</td> <td>A</td> <td>B</td> <td>C</td> <td>D</td> <td>E</td> <td>F</td> <td>G</td> <td>H</td> <td>I</td> <td>J</td> <td>K</td> <td>L</td> <td>M</td> <td>N</td> <td>O</td> </tr> </table>		!	"	#	\$	%	&	'	(	)	*	+	,	-	.	/	0	1	2	3	4	5	6	7	8	9	:	;	<	=	>	?	@	A	B	C	D	E	F	G	H	I	J	K	L	M	N	O
	!	"	#	\$	%	&	'	(	)	*	+	,	-	.	/																																			
0	1	2	3	4	5	6	7	8	9	:	;	<	=	>	?																																			
@	A	B	C	D	E	F	G	H	I	J	K	L	M	N	O																																			

			P	Q	R	S	T	U	V	W	X	Y	Z	[	\	]	^	_	
			`	a	b	c	d	e	f	g	h	i	j	k	l	m	n	o	
			p	q	r	s	t	u	v	w	x	y	z	{		}	~		

Continuation „General Menu“:

<b>SCALE UNITS (BATCH)</b>		
This parameter defines which unit should be shown on the two-line display for the batch counter. For a list of adjustable units, see parameter SCALE UNITS.		

<b>LINEARIZATION MODE</b>		
This parameter defines the linearization function. See chapter 6.1.		
0	<b>OFF</b>	No linearization
1	<b>1 QUADRANT</b>	Linearization in the 1. quadrant
2	<b>4 QUADRANT</b>	Linearization in all 4 quadrants

<b>PIN PRESELECTION</b>		
This parameter defines the PIN-code to lock the quick start of the menu PRESELECTION VALUE for entering the preselection values. (Master PIN 6079).		
This Lock function is only useful in conjunction with active lock function in PIN PARAMETER.		
	<b>0000</b>	No lock
	...	
	<b>9999</b>	Access after entering PIN-Code 9999

<b>PIN PARAMETER</b>		
This parameter defines the PIN-code for lock function of all parameters (master PIN 6079).		
	<b>0000</b>	No lock
	...	
	<b>9999</b>	Parameterization of the unit after entering PIN-code 9999

<b>BACK UP MEMORY</b>		
0	<b>NO</b>	No back memory –up by power failure
1	<b>YES</b>	Backup memory by power failure, actual value will be saved

<b>FACTORY SETTINGS</b>		
0	<b>No</b>	No default values are loaded
1	<b>Yes</b>	Load default values of all parameters (grey marked default values)

## 5.2. Mode Speed

This menu defines the operation as speed indicator (RPM), tachometer or frequency meter. In this operation mode only input A is active or Input A and Input B with 90 ° phase offset for forward / reverse rotation detection. This menu is only displayed when the appropriate OPERATIONAL MODE in GENERAL MENU is selected.

<b>DISPLAY VALUE</b>		
Desired value, which should be displayed at the setting of BASE FREQUENCY.		
	<b>1</b>	Smallest value
	<b>1000</b>	Default value
	<b>99999999</b>	Highest value

<b>BASE FREQUENCY (HZ)</b>		
Reference frequency for the desired DISPLAY VALUE.		
	<b>1</b>	Smallest value
	<b>100</b>	Default value
	<b>500000</b>	Highest value

<b>DECIMAL POINT</b>		
This value defines the position of the decimal point.		
	<b>0 NO</b>	No decimal point
	<b>1 0000000.0</b>	Decimal point at the specified position
	<b>2 000000.00</b>	Decimal point at the specified position
	<b>3 00000.000</b>	Decimal point at the specified position
	<b>4 0000.0000</b>	Decimal point at the specified position
	<b>5 000.00000</b>	Decimal point at the specified position
	<b>6 00.000000</b>	Decimal point at the specified position
	<b>7 0.0000000</b>	Decimal point at the specified position

<b>SAMPLING TIME (S)</b>		
The configured value corresponds to the minimum measurement time. The Parameter is used as a filter in case of irregular frequencies. This parameter directly affects the response time of the unit.		
	<b>0.005</b>	Shortest Sampling time
	<b>0.1</b>	Default value
	<b>9.999</b>	Longest Sampling time
<p style="text-align: right;"><math>f = \frac{6}{T}</math></p>		

Continuation „Mode Speed“:

**WAIT TIME (S)**

This parameter defines the period time of the lowest frequency, accordingly the time between two rising signal edges detecting frequency 0 Hz. Frequencies with a period time higher than the set "WAIT TIME" will be detected as frequency = 0 Hz.

<b>0.01</b>	Frequency = 0 Hz, for frequencies below 100 Hz
<b>1.00</b>	Default value
<b>80.00</b>	Frequency = 0 Hz, for frequencies below 0,01 Hz

**STANDSTILL TIME (S)**

This parameter defines the time setting for standstill definition. A time of xx.xx seconds after detection " frequency = 0 Hz " the unit signals "standstill" and reactivates the start-up-delays. Stand still detection can be set in PRESELECT MENU.

<b>0.00</b>	Shortest time
...	
<b>99.99</b>	Largest time

**AVERAGE FILTER**

Selectable average or filter function to avoid measuring fluctuations by unstable frequencies. At setting 1 to 4 a floating average calculation is performed. At settings 5 to 8, the device uses an exponential filter. The time constant T (63%) corresponds to the sampling cycles.

For example: If SAMPLING TIME = 0,1 s and AVERAGE FILTER = Exponential filter, T (63 %) = 2x SAMPLING TIME, after 0,2 seconds, 63% of the step size are reached

<b>0</b>	No average value will be created
<b>1</b>	2 numbers of floating average cycles
<b>2</b>	4 numbers of floating average cycles
<b>3</b>	8 numbers of floating average cycles
<b>4</b>	16 numbers of floating average cycles
<b>5</b>	Exponential filter, T (63 %) = 2x SAMPLING TIME
<b>6</b>	Exponential filter, T (63 %) = 4x SAMPLING TIME
<b>7</b>	Exponential filter, T (63 %) = 8x SAMPLING TIME
<b>8</b>	Exponential filter, T (63 %) = 16x SAMPLING TIME

Continuation „Mode Speed“:

<b>FOR/REV DETECTION</b>		
This parameter enables the detection of direction of rotation (Input A, Input B with 90°).		
<b>0</b>	<b>OFF</b>	Direction of rotation detection off
<b>1</b>	<b>ON</b>	Direction of rotation detection on

### 5.3. Mode Process Time

In this menu the operation is defined as baking time or processing time indicator (reciprocal speed) only input A is used. This menu is only displayed when the appropriate OPERATIONAL MODE in the GENERAL MENU is selected.

<b>DISPLAY FORMAT</b>		
This parameter selects the Display Format. The corresponding decimal point will be set automatically.		
<b>0</b>	<b>SECONDS</b>	Display in seconds
<b>1</b>	<b>MINUTES</b>	Display in minutes
<b>2</b>	<b>MIN:SEC</b>	Display in minutes : seconds
<b>3</b>	<b>MIN.00</b>	Anzeige in Minuten und 1/100 Minuten
<b>4</b>	<b>H:M:S</b>	Anzeige in Stunden : Minuten : Sekunden

<b>DISPLAY VALUE</b>		
Desired value, which should be displayed at the setting of BASE FREQUENCY.		
<b>1</b>		Smallest value
<b>1000</b>		Default value
<b>99999999</b>		Highest value

<b>BASE FREQUENCY (HZ)</b>		
Reference frequency for the desired DISPLAY VALUE.		
<b>1</b>		Smallest value
<b>100</b>		Default value
<b>500000</b>		Highest value

<b>SAMPLING TIME (S)</b>		
The configured value corresponds to the minimum measurement time. The Parameter is used as a filter in case of irregular frequencies. This parameter directly affects the response time of the unit.		
<b>0.005</b>		Shortest sampling time
<b>0.1</b>		Default value
<b>9.999</b>		Longest sampling time

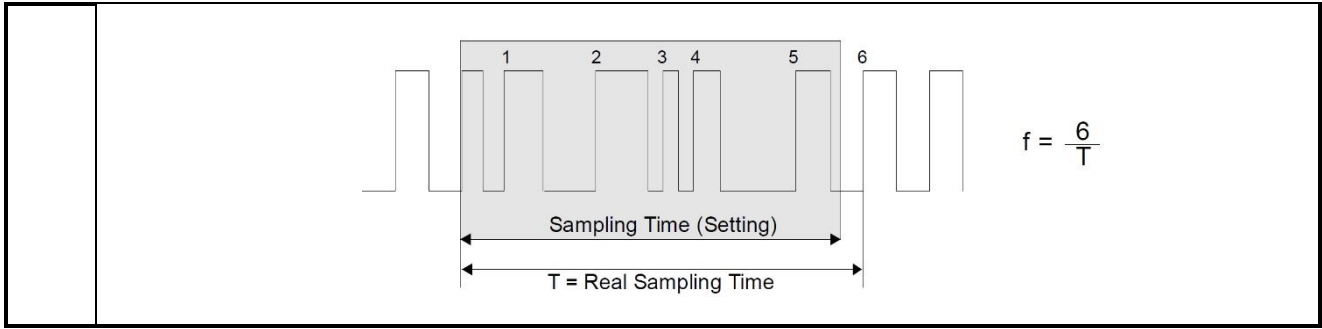



Continuation „**Mode Process Time**“:

**WAIT TIME (S)**

This parameter defines the period time of the lowest frequency, accordingly the time between two rising signal edges detecting frequency 0 Hz. Frequencies with a period time higher than the set "WAIT TIME" will be detected as frequency = 0 Hz.

<b>0.01</b>	Frequency = 0 Hz, for frequencies below 100 Hz
<b>1.00</b>	Default value
<b>80.00</b>	Frequency = 0 Hz, for frequencies below 0,01 Hz

**STANDSTILL TIME (S)**

This parameter defines the time setting for standstill definition.  
 A time of xx.xx seconds after detection " frequency = 0 Hz " the unit signals "standstill" and reactivates the start-up-delays. Stand still detection can be set in PRESELECT MENU.

<b>0.00</b>	Shortest time
...	
<b>99.99</b>	Longest time

**AVERAGE FILTER**

Selectable average or filter function to avoid measuring fluctuations by unstable frequencies. At setting 1 to 4 a floating average calculation is performed. At settings 5 to 8, the device uses an exponential filter. The time constant T (63%) corresponds to the sampling cycles.

For example: If SAMPLING TIME = 0,1 s and AVERAGE FILTER = Exponential filter, T (63 %) = 2x SAMPLING TIME, after 0,2 seconds, 63% of the step size are reached

<b>0</b>	No average value will be created
<b>1</b>	2 numbers of floating average cycles
<b>2</b>	4 numbers of floating average cycles
<b>3</b>	8 numbers of floating average cycles
<b>4</b>	16 numbers of floating average cycles
<b>5</b>	Exponential filter, T (63 %) = 2x SAMPLING TIME
<b>6</b>	Exponential filter, T (63 %) = 4x SAMPLING TIME
<b>7</b>	Exponential filter, T (63 %) = 8x SAMPLING TIME
<b>8</b>	Exponential filter, T (63 %) = 16x SAMPLING TIME



## 5.4. Mode Timer

In this menu the operation of timer or stopwatch is defined.

Depending on the parameterization only input A or both are used. This menu is only displayed when the appropriate OPERATIONAL MODE in the GENERAL MENU is selected.

<b>TIME BASE</b>		
This parameter defines the time base or resolution of the measurement.		
0	<b>1/1000 SEC</b>	Milliseconds
1	<b>1/100 SEC</b>	1/100 seconds
2	<b>1/10 SEC</b>	1/10 seconds
3	<b>SECONDS</b>	Full seconds
4	<b>MIN.00</b>	Minutes and 1/100 minutes
5	<b>MIN.0</b>	Minutes and 1/10 minutes
6	<b>MIN:SEC</b>	Minutes : Seconds (999999:59)
7	<b>MIN:SEC:00</b>	Minutes : Seconds : 1/100 seconds (9999:59:99)
8	<b>H:M:S</b>	Hours : Minutes : Seconds (9999:59:59)
9	<b>H:M</b>	Hours: Minutes (999999:59)

<b>START / STOP</b>		
This parameter defines the start/stop condition of the time measurement.		
0	<b>COUNT AT A HIGH</b>	Time measurement active at Input A is „HIGH“
1	<b>COUNT AT A LOW</b>	Time measurement active at Input A is „LOW“
2	<b>START A / STOP B</b>	A rising edge at Input A starts the time measurement, a rising edge at Input B stops the time measurement.
3	<b>PERIODE AT A</b>	Period time measurement: displays the time between two rising signal edges at Input A

<b>AUTO SET /RESET</b>		
0	<b>NO</b>	Time measurement works adding or subtracting, there is no automatic set/reset at next start. Start setting must be done via set/reset
1	<b>YES</b>	With each start, the new time measurement starts automatically at the set value of the parameter "Set Value".

<b>LATCH-FUNCTION</b>		
0	<b>NO</b>	Real time display, counting value is visible.
1	<b>YES</b>	Display shows the result of the last measurement. The time counts in the background.

<b>SET VALUE.</b>		
In case of a set / reset command (via keyboard shortcut, control input, or PC user interface), the timer is set to SET VALUE		
	<b>0</b>	Smallest value (Reset)
	...	

99999999	Highest value
----------	---------------

Continuation „**Mode Timer**“:

<b>INC / DEC MODE</b>		
When START/STOP is setting to period time measurement, the time measurement works always adding.		
0	<b>INCREMENT MODE</b>	time measurement works adding
1	<b>DECREMENT MODE</b>	time measurement works subtracting

<b>TOTAL TIME MODE</b>		
Setting of the total timer (total time measurement).		
When TOTAL TIME MODE is active, PRESELECTION serves as the preset value for the total timer.		
<u>Example:</u>		
For the total time measurement TOTAL TIME MODE has to be set to YES. The total time measurement runs parallel to the normal time measurement. If the total time measurement should be automatically reset to 0 when 1:30 (H:M) is reached, the reference source must be set e. g. to "SOURCE1" from the corresponding preselection menu to "TOTAL TIMER", the corresponding preset value e. g. "PRESELECTION 1" to "1:30" and the corresponding switching condition "MODE1" to "RESULT > = PRES -> 0"		
0	<b>NO</b>	No total time measurement
1	<b>YES</b>	Total time measurement activated

<b>TOTAL TIME SET VALUE</b>		
With a reset/set command (command „SET TOTAL TIME“ via control input) the total timer (total time measurement) is set to the value entered here. The parameter is only visible when TOTAL TIME MODE is active.		
0		Smallest value (reset)
...		
99999999		Highest value

## 5.5. Mode Counter

In this menu the operation as position indicator, impulse counting, sum of 2 inputs, difference of 2 inputs or up-down counter is defined. Input A and Input B are used. This menu is only displayed when the appropriate OPERATIONAL MODE in GENERAL MENU is selected.

<b>COUNT MODE</b>		
This parameter defines the counter operation.		
0	<b>A SINGLE</b>	Input A is a counting input. Input B defines the counting direction: „LOW“ = forward „HIGH“ = reverse
1	<b>A+B</b>	Sum counter: Impulses at A + Impulses at B
2	<b>A-B</b>	Differential counter: Impulses at A – impulses at B
3	<b>A/B 90 x1</b>	Quadrature counter: Impulses A, B with edge counting x1
4	<b>A/B 90 x2</b>	Quadrature counter: Impulses A, B with edge counting x2
5	<b>A/B 90 x4</b>	Quadrature counter: Impulses A, B with edge counting x4

<b>FACTOR</b>		
Scaling factor. With the summing mode (A+B) and the differential mode (A-B) please note that the impulse scaling factor will only affect input A		
For example: A setting of factor 1.23456 and 100000 input pulses will result in a value of 123456.		
	<b>0.00001</b>	Smallest value
	<b>1</b>	Default value
	<b>99.99999</b>	Highest value

<b>SET VALUE</b>		
In case of a reset command (via keys, Control-Inputs or PC-user interface), the counter is set to the value entered here.		
	<b>-99999999</b>	Smallest value
	<b>0</b>	Default value
	<b>+99999999</b>	Highest value

<b>DECIMAL POINT</b>		
This value defines the position of the decimal point.		
0	<b>NO</b>	No decimal point
1	<b>0000000.0</b>	Decimal point at the specified position
2	<b>000000.00</b>	Decimal point at the specified position
3	<b>00000.000</b>	Decimal point at the specified position
4	<b>0000.0000</b>	Decimal point at the specified position
5	<b>000.00000</b>	Decimal point at the specified position
6	<b>00.000000</b>	Decimal point at the specified position
7	<b>0.0000000</b>	Decimal point at the specified position

Continuation „**Mode Counter**“:

**BATCH / TOTAL MODE**

Setting of the batch counter / total counter.

The function of batch counting according to a preset value is only possible in combination with the switch condition “automatic reset to zero” (RESULT <= PRES-> 0), “automatic reset to set value (RESULT>=PRES->VALUE) or “set the counter value” (RESULT <=0-> SET).

When BATCH / TOTAL MODE is active, PRESELECTION serves as the present value (SOURCE 1-4) for the BATCH COUNTER or the TOTAL COUNTER.

Example for the batch counter:

If the batch counter should increment 1 all 1000 pulses, the value e.g. PRESELCTION 1 has to be set to 1000, the related reference source SOURCE 1 to “MEASUREMENT RESULT”, the corresponding switching condition MODE 1 to "RESULT>=PRES->0" and BATCH / TOTAL MODE to INCREMENT BATCH. Should an output be turned on after a batch amount of 33, e.g. PRESELECTION 2 has to be set to 33, the related reference source SOURCE 2 to “BATCH COUNTER” and the switching condition of MODE 2 has to be set to display value greater than or equal (RESUL>=PRES).

Example for the total counter:

For the total counter, BATCH / TOTAL MODE must be set to TOTAL COUNTER. The total counter counts here parallel to the main counter. e.g. If the total counter should automatically reset to 0, when 4000 is reached, the preset value e.g. PRESELECTION 3 must be set to “4000”, the reference source SOURCE 3 must be set to “TOTAL COUNTER” and the corresponding switching condition MODE 3 must be set to "RESULT> = PRES-> 0"

<b>0</b>	<b>OFF</b>	No batch counter and no total counter
<b>1</b>	<b>INCREMENT BATCH</b>	increment batch counter
<b>2</b>	<b>DECREMENT BATCH</b>	decrement batch counter
<b>3</b>	<b>USE INPUTS ONLY</b>	increment / decrement batch counter only by external commands (see command menu)
<b>4</b>	<b>TOTAL COUNTER</b>	Total counter is activated

**BATCH / TOTAL SET VALUE**

In case of a reset/set command („SET BATCH / TOTAL“ via control input) the batch counter / total counter is set to the BATCH / TOTAL SET VALUE. The parameter is only visible when BATCH / TOTAL MODE is active.

<b>0</b>	Smallest value
...	
<b>99999999</b>	Highest value

**ROUND LOOP VALUE**

Defines the number of steps when a round-loop function is desired.

(Round-loop function only for COUNT MODE: „A SINGLE“ or „A/B 90 x X“)

<b>0</b>	Normal display without round-loop function
...	
<b>99999999</b>	Number of steps for the round-loop function

## 5.6. Mode Velocity

In this menu the operation as a runtime measurement for speed is defined.

Input A is the start input and Input B is the stop input. This menu is only displayed when the appropriate OPERATIONAL MODE in GENERAL MENU is selected.

<b>START / STOP</b>		
Setting the start and stop condition.		
	<b>RISE TO RISE</b>	Start = rising edge at input A Stop = rising edge at input B
	<b>FALL TO FALL</b>	Start = falling edge at Input A Stop = falling edge at Input B
	<b>RISE TO FALL</b>	Start = rising edge at input A Stop = falling edge at Input B
	<b>FALL TO RISE</b>	Start = falling edge at Input A Stop = rising edge at input B

<b>DISPLAY VALUE</b>		
Desired value, which should be displayed at the setting of BASE TIME (S).		
	<b>1</b>	Smallest value
	<b>1000</b>	Default value
	<b>999999</b>	Highest value

<b>BASE TIME (S)</b>		
Reference time for the desired DISPLAY VALUE.		
	<b>0.001</b>	Smallest value
	<b>1</b>	Default value
	<b>999.999</b>	Highest value

<b>DECIMAL POINT</b>		
This value defines the position of the decimal point.		
	<b>0 NO</b>	No decimal point
	<b>1 0000000.0</b>	Decimal point at the specified position
	<b>2 000000.00</b>	Decimal point at the specified position
	<b>3 00000.000</b>	Decimal point at the specified position
	<b>4 0000.0000</b>	Decimal point at the specified position
	<b>5 000.00000</b>	Decimal point at the specified position
	<b>6 00.000000</b>	Decimal point at the specified position
	<b>7 0.0000000</b>	Decimal point at the specified position



Continuation „Mode Velocity“:

**WAIT TIME (S)**

This parameter defines the period time of the lowest frequency, accordingly the time between two rising signal edges detecting frequency 0 Hz. Frequencies with a period time higher than the set "WAIT TIME" will be detected as frequency = 0 Hz.

<b>0.00</b>	The display value is retained until a new value is determined.
<b>0.01</b>	Frequency = 0 Hz, for frequencies below 100 Hz
...	
<b>99.99</b>	Frequency = 0 Hz, for frequencies below 0,01 Hz

**STANDSTILL TIME**

This parameter defines the time setting for standstill definition.  
 A time of xx.xx seconds after detection " frequency = 0 Hz " the unit signals "standstill" and reactivates the start-up-delays. Stand still detection can be set in PRESELECT MENU.  
 This STANDSTILL TIME is suitable at WAIT TIME unequal 0.000 only.

<b>0.00</b>	Shortest time
...	
<b>99.99</b>	Longest time

## 5.7. Preselection Values

This menu is used to set the preselection values or the switching points.

The preselection values are always referred to the selected SOURCE of the PRESELECTION MENU.

<b>PRESELECTION 1</b>		
Preselection / switching point 1		
	<b>-99999999</b>	Smallest value
	<b>1000</b>	Default value
	<b>+99999999</b>	Highest value

<b>PRESELECTION 2</b>		
Preselection / switching point 2		
	<b>-99999999</b>	Smallest value
	<b>2000</b>	Default value
	<b>+99999999</b>	Highest value

<b>PRESELECTION 3</b>		
Preselection / switching point 3		
	<b>-99999999</b>	Smallest value
	<b>3000</b>	Default value
	<b>+99999999</b>	Highest value

<b>PRESELECTION 4</b>		
Preselection / switching point 4		
If the BATCH / TOTAL MODE or TOTAL TIME MODE is active, the batch counter / total counter or total timer is compared with the preselection value 4.		
	<b>-99999999</b>	Smallest value
	<b>4000</b>	Default value
	<b>+99999999</b>	Highest value

## 5.8. Preselection 1 Menu

In this menu, the parameters of the reference source, the switching conditions and further definitions for preset value / switching point 1 are defined.

<b>SOURCE 1</b>		
This parameter defines the reference source for preselection 1		
<b>0</b>	<b>MEASUREMENT RESULT</b>	Reference source is the measurement result of the selected operating mode
<b>1</b>	<b>COUNTER A</b>	Reference source is the counter reading of channel A. (only visible in mode COUNTER → COUNT MODE: A+B or A-B)
<b>2</b>	<b>COUNTER B</b>	Reference source is the counter reading of channel B. (only visible in mode COUNTER → COUNT MODE: A+B or A-B)
<b>3</b>	<b>BATCH COUNTER</b>	Reference source is the batch counter. (only visible in mode COUNTER → BATCH / TOTAL MODE: INCREMENT BATCH, DECREMENT BATCH or USE INPUTS ONLY)
<b>4</b>	<b>TOTAL COUNTER</b>	Reference source is total counter. (only visible in mode COUNTER → BATCH / TOTAL MODE: TOTAL COUNTER)
<b>5</b>	<b>TOTAL TIMER</b>	Reference source is the total timer. (only visible in mode TIMER → TOTAL TIME MODE: YES)

Continuation „PRESELECTION 1 MENU“:

<b>MODE 1</b>		
Switching conditions for preselection 1. Output/ relay/ display switches under the following conditions:		
<b>0</b>	<b> RESULT &gt;= PRES </b>	Absolute value of the display value is greater or equal absolute value of PRESELECTION 1 With HYSTERESIS 1 not equal 0 the following switching condition is applied: Display value >= PRESELECTION 1 → ON, Display value < PRESELECTION 1 – HYSTERESIS 1 → OFF
<b>1</b>	<b> RESULT &lt;= PRES </b>	Absolute value of the display value is less or equal absolute value of PRESELECTION 1 (start-up suppression (START UP DELAY) is advisable) With HYSTERESIS 1 not equal 0 the following switching condition is applied: Display value <= PRESELECTION 1 → ON, Display value > PRESELECTION 1 + HYSTERESIS 1 → OFF
<b>2</b>	<b> RESULT = PRES </b>	Absolute value of the display value is equal absolute value of PRESELECTION 1 A range (Preselection +/- ½ Hysteresis) can be defined and monitored in conjunction with the hysteresis. With HYSTERESIS 1 not equal 0 the following switching condition is applied: Display value > PRESELECTION 1 + ½ HYSTERESIS 1 → OFF, Display value < PRESELECTION 1 - ½ HYSTERESIS 1 → OFF
<b>3</b>	<b>RESULT&gt;=PRES</b>	Display value is greater or equal PRESELECTION 1, e.g. overspeed With HYSTERESIS 1 not equal 0 the following switching condition is applied: Display value >= PRESELECTION 1 → ON, Display value < PRESELECTION 1 – HYSTERESIS 1 → OFF
<b>4</b>	<b>RESULT&lt;=PRES</b>	Display value is less or equal PRESELECTION 1, e.g. underspeed (start-up suppression (START UP DELAY) is advisable) With HYSTERESIS 1 not equal 0 the following switching condition is applied: Display value <= PRESELECTION 1 → ON, Display value > PRESELECTION 1 + HYSTERESIS 1 → OFF
<b>5</b>	<b>RESULT=PRES</b>	Display value is equal PRESELECTION 1. A range (Preselection +/- ½ Hysteresis) can be defined and monitored in conjunction with the hysteresis. With HYSTERESIS 1 not equal 0 the following switching condition is applied: Display value > PRESELECTION 1 + ½ HYSTERESIS 1 → OFF, Display value < PRESELECTION 1 - ½ HYSTERESIS 1 → OFF
<b>6</b>	<b>RESULT=0</b>	Display value is zero (Standstill after STANDSTILL TIME(s)), e. g. standstill monitoring, (only in mode SPEED and PROCESS TIME).
<b>7</b>	<b>RESULT&gt;= PRES-&gt;0</b>	Auto reset to zero: (only in mode TIMER or COUNTER) Display value is greater or equal PRESELECTION 1, the display value is set to zero.

		If the BATCH MODE is active, the batch counter increments or decrements when the display value is set to zero and when the corresponding source of supply MEASUREM. RESULT, COUNTER A or COUNTER B was selected.
<b>8</b>	<b>RESULT&lt;= 0-&gt;SET</b>	Auto set to PRESELECTION 1: (only in mode TIMER or COUNTER) Display value is less or equal zero, the display value is set to PRESELECTION 1 If the BATCH MODE is active, the batch counter increments or decrements when the display value is set to PRESELECTION 1 and when the corresponding source of supply MEASUREM. RESULT, COUNTER A or COUNTER B was selected.
<b>9</b>	<b>RES&gt;=PRES-TRAIL</b>	Trailing PRESELECTION 1: Display value is greater or equal PRESELECTION 2 – PRESELECTION 1 → ON, PRESELECTION 1 is the trailing value from PRESELECTION 2
<b>10</b>	<b>RESULT&gt;= PRES-&gt;VALUE</b>	Auto reset to “SET VALUE”: (only in mode TIMER or COUNTER) Display value is greater or equal PRESELECTION 1, the display value is set to the respective “SET VALUE”. If the BATCH MODE is active, the batch counter increments or decrements, when the display value is set to the respective “SET VALUE” and when the corresponding source of supply MEASUREM. RESULT, COUNTER A or COUNTER B was selected.
<b>11</b>	<b>ERROR SET</b>	Error message for device errors

**HYSTERESIS 1**

This parameter defines the switching hysteresis of the switch-off point for preselection 1

	<b>0</b>	No switching hysteresis
	...	
	<b>9999</b>	Switching hysteresis of 99999

**PULSE TIME 1 (S)**

Duration of output pulse for the switching condition of preselection 1

	<b>0.000</b>	No output pulse (static signal)
	...	
	<b>60.000</b>	Pulse duration of 60 seconds

**OUTPUT TARGET 1**

Assignment of an output or relay for the switching condition of preselection 1.

If more than one switching condition is assigned to one output / relay, the output is set when at least one switching condition is true

<b>0</b>	<b>NO</b>	No assignment
<b>1</b>	<b>CTRL OUT 1</b>	Switching condition assigned to “Ctrl. Out 1”
<b>2</b>	<b>CTRL OUT 2</b>	Switching condition assigned to “Ctrl. Out 2”
<b>3</b>	<b>CTRL OUT 3</b>	Switching condition assigned to “Ctrl. Out 3”
<b>4</b>	<b>CTRL OUT 4</b>	Switching condition assigned to “Ctrl. Out 4”
<b>5</b>	<b>RELAY 1</b>	Switching condition assigned to “Rel. 1”

6	<b>RELAY 2</b>	Switching condition assigned to "Rel. 2"
---	----------------	--

<b>OUTPUT POLARITY 1</b>		
Polarity for the switching condition of preselection 1		
0	<b>ACTIVE HIGH</b>	Switching condition is true → Active „HIGH“
1	<b>ACTIVE LOW</b>	Switching condition is true → Active „LOW“

Continuation „PRESELECTION 1 MENU“:

<b>OUTPUT LOCK 1</b>		
Latch for the switching condition of preselection 1		
0	<b>NO</b>	No latch for preselection
1	<b>YES</b>	Latch for preselection (command LOCK RELEASE will clear latch)

<b>START UP DELAY 1 (S)</b>		
Start-up suppression for the switching condition of preselection 1. This adjustment is only valid for the switching condition  RESULT <= PRES  or RESULT<=PRES and mode SPPED and PROCESS TIME. (Start Up Delay 3 and 4 have an automatic start up suppression).		
	<b>00.000</b>	No start-up suppression
	...	
	<b>60.000</b>	Start-up suppression in seconds

<b>EVENT COLOR 1</b>		
Event-dependending change of the display color for the switching condition of preselection 1. EVENT COLOR 1 has the lowest priority. EVENT COLOR 2 ... 4 are allowed to overwrite this color change.		
0	<b>NO CHANGE</b>	No color change.
1	<b>CHANGE TO RED</b>	Color change to red
2	<b>CHANGE TO GREEN</b>	Color change to green
3	<b>CHANGE TO YELLOW</b>	Color change to yellow

## 5.9. Preselection 2 Menu

### SOURCE 2

The reference source for PRESELECTION 2, see PRESELECTION 1 MENU.

### MODE 2

Switching conditions for preselection 2. Output/ relay/ display switches under the following conditions:

		See chapter PRESELECTION 1 MENU
9	RES>=PRES-TRAIL	Trailing preselection 2: Display value is greater or equal to PRESELECTION 1 – PRESELECTION 2 → ON, PRESELECTION 2 is the trailing preselection from PRESELECTION 1.

### HYSTERESIS 2

This parameter defines the switching hysteresis of the switch-off point for preselection 2.  
See chapter PRESELECTION 1 MENU.

### PULSE TIME 2 (S)

Duration of output pulse for the switching condition of preselection 2.  
See chapter PRESELECTION 1 MENU.

### OUTPUT TARGET 2

Assignment of an output or relay for the switching condition of preselection 2.  
See chapter PRESELECTION 1 MENU.

### OUTPUT POLARITY 2

Polarity for the switching condition of preselection 2.  
See chapter PRESELECTION 1 MENU.

### OUTPUT LOCK 2

Latch for the switching condition of preselection 2.  
See chapter PRESELECTION 1 MENU.

### START UP DELAY 2 (S)

Start-up suppression for the switching condition of preselection 2.  
See chapter PRESELECTION 1 MENU.  
(Start Up Delay 3 and 4 have an automatic start up suppression).

### EVENT COLOR 2

Event-depending change of the display color for the switching condition of preselection 2.  
See chapter PRESELECTION 1 MENU.

## 5.10. Preselection 3 Menu

### SOURCE 3

The reference source for PRESELECTION 3, see PRESELECTION 1 MENU.

### MODE 3

Switching conditions for preselection 3. Output/ relay/ display switches under the following conditions:

		See chapter PRESELECTION 1 MENU
9	RES>=PRES-TRAIL	Trailing preselection 3: Display value is greater or equal to PRESELECTION 4 – PRESELECTION 3 → ON, PRESELECTION 3 is the trailing preselection from PRESELECTION 4.

### HYSTERESIS 3

This parameter defines the switching hysteresis of the switch-off point for preselection 3.  
See chapter PRESELECTION 1 MENU.

### PULSE TIME 3 (S)

Duration of output pulse for the switching condition of preselection 3.  
See chapter PRESELECTION 1 MENU.

### OUTPUT TARGET 3

Assignment of an output or relay for the switching condition of preselection 3.  
See chapter PRESELECTION 1 MENU.

### OUTPUT POLARITY 3

Polarity for the switching condition of preselection 3.  
See chapter PRESELECTION 1 MENU.

### OUTPUT LOCK 3

Latch for the switching condition of preselection 3.  
See chapter PRESELECTION 1 MENU.

### START UP DELAY 3

Start-up suppression for the switching condition of preselection 3.  
This adjustment is only valid for the switching condition |RESULT|<=|PRES| or RESULT<=PRES and mode SPPED and PROCESS TIME. (Start Up Delay 1 and 2 have a time-dependent start up suppression).

0	OFF	No start-up suppression
1	AUTO	Automatic start up suppression, until the preselection value / switching point is exceeded for the first time.

### EVENT COLOR 3

Event-dependending change of the display color for the switching condition of preselection 3.  
See chapter PRESELECTION 1 MENU.





## 5.11. Preselection 4 Menu

<b>SOURCE 4</b>		
The reference source for PRESELECTION 4, see PRESELECTION 1 MENU.		
<b>MODE 4</b>		
Switching conditions for preselection 4. Output/ relay/ display switches under the following conditions:		
		See chapter PRESELECTION 1 MENU
9	<b>RES&gt;=PRES-TRAIL</b>	Trailing preselection 4: Display value is greater or equal to PRESELECTION 3 – PRESELECTION 4 → ON, PRESELECTION 4 is the trailing preselection from PRESELECTION 3.
<b>HYSTERESIS 4</b>		
This parameter defines the switching hysteresis of the switch-off point for preselection 4. See chapter PRESELECTION 1 MENU.		
<b>PULSE TIME 4 (S)</b>		
Duration of output pulse for the switching condition of preselection 3. See chapter PRESELECTION 1 MENU.		
<b>OUTPUT TARGET 4</b>		
Assignment of an output or relay for the switching condition of preselection 4. See chapter PRESELECTION 1 MENU.		
<b>OUTPUT POLARITY 4</b>		
Polarity for the switching condition of preselection 4. See chapter PRESELECTION 1 MENU.		
<b>OUTPUT LOCK 4</b>		
Latch for the switching condition of preselection 4. See chapter PRESELECTION 1 MENU.		
<b>START UP DELAY 4</b>		
Start-up suppression for the switching condition of preselection 4. This adjustment is only valid for the switching condition $ RESULT  \leq  PRES $ or $RESULT \leq PRES$ and mode SPPED and PROCESS TIME. (Start Up Delay 1 and 2 have a time-dependent start up suppression).		
	<b>0 OFF</b>	No start-up suppression
	<b>1 AUTO</b>	Automatic start up suppression, until the preselection value / switching point is exceeded for the first time.
<b>EVENT COLOR 4</b>		
Event-depending change of the display color for the switching condition of preselection 4. See chapter PRESELECTION 1 MENU.		



## 5.12. Serial Menu

This menu defines the basic settings of serial interface.

<b>UNIT NUMMER</b>		
This parameter defines serial device addresses. The addresses between 11 and 99 can be assigned to the devices. Addresses with zero are not allowed, there are used as broadcast addresses.		
	<b>11</b>	Smallest address
	...	
	<b>99</b>	Highest address

<b>SERIAL BAUD RATE</b>			
This parameter defines the serial baud rate			
	<b>0</b>	<b>9600</b>	9600 baud
	<b>1</b>	<b>19200</b>	19200 baud
	<b>2</b>	<b>38400</b>	38400 baud

<b>SERIAL FORMAT</b>					
This parameter defines the bit data format.					
	<b>0</b>	<b>7-EVEN-1</b>	7 data	Parity even	1 Stop
	<b>1</b>	<b>7-EVEN-2</b>	7 data	Parity even	2 Stops
	<b>2</b>	<b>7-ODD-1</b>	7 data	Parity odd	1 Stop
	<b>3</b>	<b>7-ODD-2</b>	7 data	Parity odd	2 Stops
	<b>4</b>	<b>7-NONE-1</b>	7 data	no Parity	1 Stop
	<b>5</b>	<b>7-NONE-2</b>	7 data	no Parity	2 Stops
	<b>6</b>	<b>8-EVEN-1</b>	8 data	Parity even	1 Stop
	<b>7</b>	<b>8-ODD-1</b>	8 data	Parity odd	1 Stop
	<b>8</b>	<b>8-NONE-1</b>	8 data	no Parity	1 Stop
	<b>9</b>	<b>8-NONE-2</b>	8 data	no Parity	2 Stops

<b>SERIAL INIT</b>			
This parameter defines the baud rate for the initialization to the user interface OS6.0. With settings larger than 9600 the initialization time can be reduced.			
	<b>0</b>	<b>NO</b>	Initialization with 9600 baud. Then the device operates with the value selected by the user.
	<b>1</b>	<b>YES</b>	Initialization with the baud rate set by SERIAL BAUD RATE. Then the device operates with the value selected by the user.

Continuation „Serial Menu“:

**SERIAL PROTOCOL**

Determines the sequence of characters send, when using the serial output for cyclic data transmission under time control (xxxxxxx = value SERIAL VALUE).

Setting „1“ removes the unit address from the string which allows a slight faster transmission cycle.

<b>0</b>	Transmission report = Unit Nr., +/-, data, LF, CR											
	<table border="1" style="margin-left: auto; margin-right: auto;"> <tr> <td>1</td><td>1</td><td>+/-</td><td>X</td><td>X</td><td>X</td><td>X</td><td>X</td><td>X</td><td>X</td><td>LF</td><td>CR</td> </tr> </table>	1	1	+/-	X	X	X	X	X	X	X	LF
1	1	+/-	X	X	X	X	X	X	X	LF	CR	
<b>1</b>	Transmission report = +/-, data, LF, CR											
	<table border="1" style="margin-left: auto; margin-right: auto;"> <tr> <td>+/-</td><td>X</td><td>X</td><td>X</td><td>X</td><td>X</td><td>X</td><td>X</td><td>LF</td><td>CR</td> </tr> </table>	+/-	X	X	X	X	X	X	X	LF	CR	
+/-	X	X	X	X	X	X	X	LF	CR			

**SERIAL TIMER (S)**

This register determines the cycle time in seconds for cycling transmission of SERIAL VALUE when using the serial output. (On a serial request, the cycling transmission is stopped for 20 s)

<b>0.000</b>	All cyclic transmission is switched off. The unit will send data upon a serial request or with command SERIAL PRINT.
...	
<b>60.000</b>	Cycle time in seconds.

**SERIAL VALUE**

This parameter defines the value to be transmitted.

Setting	Code	Register contents
<b>0</b>	:0	Measurement_Result
<b>1</b>	:1	Speed_Value
<b>2</b>	:2	Time_Result
<b>3</b>	:3	Counter
<b>4</b>	:4	Velocity_Speed
<b>5</b>	:5	Batch_Counter
<b>6</b>	:6	Minimal_Value
<b>7</b>	:7	Maximal_Value
<b>8</b>	:8	Counter_Total
<b>9</b>	:9	Time_Result_Total

**MODBUS**

This parameter enables the Modbus protocol and determines the Modbus address.

For details of the Modbus communication please refer to the additional manual Modbus\_RTU

<b>0</b>	Modbus disabled Serial interface is using Lecom protocol
<b>1 ... 247</b>	Modbus enabled: Serial interface is using Modbus RTU protocol The set value is the Modbus address of the device.



### 5.13. Analog Menu

This menu defines the basic settings of the analog output.

<b>ANALOG SOURCE</b>		
This parameter defines the reference source for analog output		
<b>0</b>	<b>MEASUREMENT RESULT</b>	Reference source is the measurement result of the selected operating mode.
<b>1</b>	<b>COUNTER A</b>	Reference source is the counter reading of channel A. (only visible in mode COUNTER → COUNT MODE: A+B or A-B)
<b>2</b>	<b>COUNTER B</b>	Reference source is the counter reading of channel B. (only visible in mode COUNTER → COUNT MODE: A+B or A-B)
<b>3</b>	<b>BATCH COUNTER</b>	Reference source is the batch counter. (only visible in mode COUNTER → BATCH / TOTAL MODE: INCREMENT BATCH, DECREMENT BATCH or USE INPUTS ONLY)
<b>4</b>	<b>TOTAL COUNTER</b>	Reference source is total counter. (only visible in mode COUNTER → BATCH / TOTAL MODE: TOTAL COUNTER)
<b>5</b>	<b>TOTAL TIMER</b>	Reference source is the total timer. (only visible in mode TIMER → TOTAL TIME MODE: YES)

<b>ANALOG FORMAT</b>		
This parameter defines the output characteristics. The analogue output is proportional to the display value.		
With setting ANALOG FORMAT (-10 ... +10 V) in MODE COUNTER the polarity of the analog output depends on the polarity of the display value.		
<b>0</b>	<b>-10...10V</b>	-10 ... +10 V
<b>1</b>	<b>0...20M</b>	0 ... 20 mA
<b>2</b>	<b>4...20MA</b>	4 ... 20 mA

<b>ANALOG START</b>		
This parameter defines the start value of the analog conversion. This start value is corresponding to the display value for an analog output of 0 V or 0/4 mA.		
	<b>-99999999</b>	Smallest start value
	<b>0</b>	Default value
	<b>+99999999</b>	Highest start value

<b>ANALOG END</b>		
This parameter defines the end value of the analog conversion. This end value is corresponding to the display value for an analog output of (+/-) 10 V or 20mA.		
	<b>-99999999</b>	Smallest end value
	<b>10000</b>	Default Wert
	<b>+99999999</b>	Highest end value

<b>ANALOG GAIN (%)</b>		
This parameter specifies the maximum conversion of the analog output in %.		
e. g. 102.00 corresponds to a conversion of 10.2 V or 20.4 mA, when the ANALOG END value is reached.		

e. g. 95.00 corresponds to a conversion of 9.5 V or 18 mA, when the ANALOG END value is reached.

	<b>0</b>	Smallest gain
	<b>100</b>	Default value
	<b>110</b>	Highest gain

Continuation „**Analog MENU**“:

**ANALOG OFFSET (%)**

This parameter defines the zero offset of the analog output.

z. B. 0.20 result in an offset of 0.02 V or 0.04 mA at ANALOG START value

	<b>-99.99</b>	Smallest offset
	<b>0</b>	Default value
	<b>+99.00</b>	Highest offset



## 5.14. Command Menu

<b>INPUT 1 ACTION</b> _(function Input 1)			
This parameter defines the function of the input "Ctrl. In 1".			
<b>0</b>	<b>NO</b>	No function	
<b>1</b>	<b>RESET/SET VALUE</b>	Mode Timer: Reset the value to 0. Mode Counter: Reset / set the value from channel A and B to „SET VALUE“. Mode Velocity: Reset the value to 0.	(d) (s)
<b>2</b>	<b>FREEZE</b>	Freeze actual display value	(s)
<b>3</b>	<b>KEY LOCK</b>	disable touch screen	(s)
<b>4</b>	<b>LOCK RELEASE</b>	Loosen locking of all outputs / relay	(d)
<b>5</b>	<b>RESET MIN/MAX</b>	Reset of the min. / max. values	(d) (s)
<b>6</b>	<b>SERIAL PRINT</b>	Sending of serial data, see parameter SERIAL VALUE	(d)
<b>7</b>	<b>TEACH PRESEL. 1</b>	Current display value is stored as PRESELECTION 1	(d)
<b>8</b>	<b>TEACH PRESEL. 2</b>	Current display value is stored as PRESELECTION 2	(d)
<b>9</b>	<b>TEACH PRESEL. 3</b>	Current display value is stored as PRESELECTION 3	(d)
<b>10</b>	<b>TEACH PRESEL. 4</b>	Current display value is stored as PRESELECTION 4	(d)
<b>11</b>	<b>SCROLL DISPLAY</b>	Display switching (see display in operation mode)	(d)
<b>12</b>	<b>CLEAR LOOP TIME</b>	Release all latched switching conditions	
<b>13</b>	<b>START PRESELECT</b>	N.A.	
<b>14</b>	<b>ACTIVATE</b>	N.A.	
<b>15</b>	<b>STORE DATA</b>	N.A.	
<b>16</b>	<b>TESTPROGRAM</b>	N.A.	
<b>17</b>	<b>SET RED COLOR</b>	The display lights up red. The color can be changed by the event-dependent color switching in the PRESELECTION 1... 4	(d)
<b>18</b>	<b>SET GREEN COLOR</b>	The display lights up green. The color can be changed by the event-dependent color switching in the PRESELECTION 1... 4	(d)
<b>19</b>	<b>SET YELLOW COLOR</b>	The display lights up yellow The color can be changed by the event-dependent color switching in the PRESELECTION 1... 4	(d)
<b>20</b>	<b>INCREMENT BATCH</b>	Increase the batch counter (see mode counter)	(d)
<b>21</b>	<b>DECREMENT BATCH</b>	Decrease of the batch counter (see mode counter)	(d)
<b>22</b>	<b>SET BATCH / TOTAL</b>	Reset / set the value of the batchcounter / totalcounter (see Mode Counter)	(d) (s)
<b>23</b>	<b>INC. BRIGHTNESS</b>	Display brightness is increased	(d) (s)
<b>24</b>	<b>DEC. BRIGHTNESS</b>	Display brightness is reduced	(d) (s)
<b>25</b>	<b>SET TOTAL TIME</b>	Reset / set the total time measurement (see Mode TIMER)	(d) (s)
<b>26</b>	<b>SET COUNTER A</b>	Reset /set the value of counter from port A to the set value in SET VALUE - only in Mode „COUNTER“ possible	(d) (s)
<b>27</b>	<b>SET COUNTER B</b>	Reset /set the value of counter from port B to the set value in SET VALUE - only in Mode „COUNTER“ possible	(d) (s)
<b>28</b>	<b>LOCK COUNTER A</b>	Counter (channel A) is disabled and stops counting any further pulses as long as this command is present.	(s)

	<b>29</b>	<b>LOCK COUNTER B</b>	Counter (channel B) is disabled and stops counting any further pulses as long as this command is present.	(s)
--	-----------	-----------------------	---	-----

(s) = static switching (level evaluation)  
 INPUT CONFIG must be set to active LOW / HIGH

(d) = dynamic switching (edge evaluation)  
 INPUT CONFIG must be set to RISING/FALLING EDGE

<b>INPUT 1 CONFIG</b>		
This parameter defines the switching characteristics of the input "Ctrl. In 1".		
<b>0</b>	<b>ACTIVE LOW</b>	Active at „LOW“ (static)
<b>1</b>	<b>ACTIVE HIGH</b>	Active at „HIGH“ (static)
<b>2</b>	<b>RISING EDGE</b>	Activate at rising edge
<b>3</b>	<b>FALLING EDGE</b>	Activate at falling edge

<b>INPUT 2 ACTION</b>
This parameter defines the function of the input "Ctrl. In 2". See parameter INPUT 1 ACTION.

<b>INPUT 2 CONFIG</b>
This parameter defines the switching characteristics of the input "Ctrl. In 2". See parameter INPUT 1 CONFIG.

<b>INPUT 3 ACTION</b>
This parameter defines the function of the input "Ctrl. In 3". See parameter INPUT 1 ACTION.

<b>INPUT 3 CONFIG</b>
This parameter defines the switching characteristics of the input "Ctrl. In 3". See parameter INPUT 1 CONFIG.

## 5.15. Display Menu

Parameter changes become active only after closing the menu selection.

<b>SOURCE DUAL TOP</b>		
(Reference source for two-line display , first line)		
0	<b>MEASUREMENT RESULT</b>	Reference source is the measurement result of the selected operating mode.
1	<b>COUNTER A</b>	Reference source is the counter reading of channel A. (only visible in mode COUNTER → COUNT MODE: A+B or A-B)
2	<b>COUNTER B</b>	Reference source is the counter reading of channel B. (only visible in mode COUNTER → COUNT MODE: A+B or A-B)
3	<b>BATCH COUNTER</b>	Reference source is the batch counter. (only visible in mode COUNTER → BATCH / TOTAL MODE: INCREMENT BATCH, DECREMENT BATCH or USE INPUTS ONLY)
4	<b>TOTAL COUNTER</b>	Reference source is total counter. (only visible in mode COUNTER → BATCH / TOTAL MODE: TOTAL COUNTER)
5	<b>TOTAL TIMER</b>	Reference source is the total timer. (only visible in mode TIMER → TOTAL TIME MODE: YES)

<b>SOURCE DUAL DOWN</b>		
(Reference source for two-line display , second line)		
0	<b>MEASUREMENT RESULT</b>	Reference source is the measurement result of the selected operating mode.
1	<b>COUNTER A</b>	Reference source is the counter reading of channel A. (only visible in mode COUNTER → COUNT MODE: A+B or A-B)
2	<b>COUNTER B</b>	Reference source is the counter reading of channel B. (only visible in mode COUNTER → COUNT MODE: A+B or A-B)
3	<b>BATCH COUNTER</b>	Reference source is the batch counter. (only visible in mode COUNTER → BATCH / TOTAL MODE: INCREMENT BATCH, DECREMENT BATCH or USE INPUTS ONLY)
4	<b>TOTAL COUNTER</b>	Reference source is total counter. (only visible in mode COUNTER → BATCH / TOTAL MODE: TOTAL COUNTER)
5	<b>TOTAL TIMER</b>	Reference source is the total timer. (only visible in mode TIMER → TOTAL TIME MODE: YES)

<b>COLOR</b>		
This parameter defines the display color. Event-depending change of the display color by a switching condition is possible (see PRESELECTION 1...4 MENU)		
0	<b>RED</b>	Red display
1	<b>GREEN</b>	Green display
2	<b>YELLOW</b>	Yellow display

<b>BRIGHTNESS (%)</b>		
This parameter defines the brightness of the display in percent		

	<b>10</b>	Min. brightness
	<b>90</b>	Default value
	<b>100</b>	Max. brightness

Continuation “**Display Menu**”:

<b>CONTRAST</b>		
This parameter defines the viewing angle.		
	<b>0</b>	Viewing angle from top
	<b>1</b>	Viewing angle from center
	<b>2</b>	Viewing angle from bottom

<b>SCREEN SAVER (S)</b>		
This parameter defines the time in seconds until the display is switched off, after the last touch action. A new touch action will activate the display again.		
	<b>0</b>	No switch off
	...	
	<b>99.99</b>	Longest time to switch off

<b>UP-DATE-TIME (S)</b>		
This parameter defines the update time in seconds of the display only.		
	<b>0.005</b>	Shortest update time
	<b>0.1</b>	Default value
	<b>9.999</b>	Longest update time

<b>FONT</b>		
This parameter defines the setting of the font style.		
	<b>0</b>	Standard
	<b>1</b>	Font 1

<b>START DISPLAY</b>			
This parameter defines the start display after switching on device.			
	<b>0</b>	<b>STANDARD</b>	Display with unit and status bar
	<b>1</b>	<b>DOUBLE</b>	Two-line display without units (only the parameter „ <b>BATCH TOTAL MODE</b> “ or <b>TOTAL TIME MODE</b> “ or „ <b>COUNT MODE A+B / A-B</b> is active)
	<b>2</b>	<b>DOUBLE WITH UNITS</b>	Two-line display with units (only the parameter „ <b>BATCH TOTAL MODE</b> “ or <b>TOTAL TIME MODE</b> “ or „ <b>COUNT MODE A+B / A-B</b> is active)
	<b>3</b>	<b>LARGE</b>	Large display (only the parameter „ <b>LARGE DISPLAY</b> “ is active)
	<b>4</b>	<b>COMMAND</b>	Display with command keys (only with operating mode <b>TIMER</b> or <b>COUNTER</b> )

5	<b>QUICKSTART</b>	Display for quick start for enter preselection values
6	<b>MINIMUM/MAXIMUM</b>	Display with minimum and maximum value

Continuation “**Display Menu**”:

<b>LARGE DISPLAY</b>		
This parameter defines to switch on / off the large display.		
By splitting ratio the display value for the large display can be divided.		
(Applies only for all 99999999 number formats!)		
<b>0</b>	<b>NO</b>	Large display off
<b>1</b>	<b>1:1</b>	Large display with splitting ratio 1:1
<b>2</b>	<b>1:10</b>	Large display with splitting ratio 1:10
<b>3</b>	<b>1:100</b>	Large display with splitting ratio 1:100
<b>4</b>	<b>1:1000</b>	Large display with splitting ratio 1:1000
<b>5</b>	<b>1:10000</b>	Large display with splitting ratio 1:10000

### 5.16. Linearization Menu

The linearization function is defined in this menu. The linearization points are only used in operation mode SPEED, PROCESS TIME or COUNTER. This menu will only be showed, if the LINEARIZATION MODE in GENERAL MENU is selected.

Linearization description and examples are shown in the appendix.

<b>P1(X) - P24(X)</b>		
X-coordinate of the linearization point.		
This value representing the display value which the unit show in the display without linearization.		
	<b>-99999999</b>	Smallest X-coordinate
	<b>0</b>	Default value
	<b>+99999999</b>	Largest X-coordinate

<b>P1(Y) - P24(Y)</b>		
Y-coordinate of the linearization point		
This is the display value, which the unit should show in the display with linearization.		
E.g. P2(X) is replaced by P2(Y).		
	<b>-99999999</b>	Smallest Y-coordinate
	<b>0</b>	Default value
	<b>+99999999</b>	Largest Y-coordinate

## 6. Appendix

### 6.1. Data readout via serial interface

All codes shown in the parameter SERIAL VALUE are available for serial readout by PC or PLC. The communication of these devices is based on the Drivecom protocol according to ISO 1745 or the Modbus RTU protocol. All protocol details can be found in our manual SERPRO (Drivecom) which is available in the chapter “Modbus RTU Interface” in this manual.

**To request for a data transmission you must send the following request string to the converter:**

EOT	AD1	AD2	C1	C2	ENQ
-----	-----	-----	----	----	-----

- EOT = control character (Hex 04)
- AD1 = unit address, High Byte
- AD2 = unit address, Low Byte
- C1 = register code, High Byte
- C2 = register code, Low Byte
- ENQ = control character (Hex 05)

The following example shows the request string for readout of the actual input frequency of a monitor (Code=1) from a unit with unit address 11:

ASCII-Code:	EOT	1	1	:	1	ENQ
Hex-Code:	04	31	31	3A	31	05
Binary-Code:	0000 0100	0011 0001	0011 0001	0011 1010	0011 0001	0000 0101

**After a correct request, the unit will respond:**

STX	C1	C2	xxxxx	ETX	BCC
-----	----	----	-------	-----	-----

- STX = control character (Hex 02)
- C1 = register code, High Byte
- C2 = register code, Low Byte
- xxxxx = readout data
- ETX = control character (Hex 03)
- BCC = block check character

## 6.2. Modbus RTU Interface

The Modbus interface of the touchMatrix® series is a standard Modbus RTU Slave and provides the following Modbus functions:

- Read Coils
- Write Single Coil
- Read Holding Registers
- Write Multiple Registers
- Diagnosis

For the operation of the interface module and the understanding of this manual basic knowledge in Modbus RTU communication is presupposed.

### 6.2.1. Parameter setting

Required parameter settings in “Serial menu”:

<b>UNIT NUMMER</b>		
Not valid for Modbus communication (For setting of Modbus address see parameter “MODBUS”)		

<b>SERIAL BAUD RATE</b>		
This parameter defines the serial baud rate		
0	<b>9600</b>	9600 baud
1	<b>19200</b>	19200 baud
2	<b>38400</b>	38400 baud

<b>SERIAL FORMAT</b>				
This parameter defines the bit data format.				
0	7-EVEN-1	Do not use with Modbus protocol		
1	7-EVEN-2			
2	7-ODD-1			
3	7-ODD-2			
4	7-NONE-1			
5	7-NONE-2			
6	<b>8-EVEN-1</b>	8 data bits	Parity even	1 stop bit
7	<b>8-ODD-1</b>	8 data bits	Parity odd	1 stop bit
8	8-NONE-1	Do not use with Modbus protocol		
9	<b>8-NONE-2</b>	8 data bits	no Parity	2 stop bits



Continuation “Parameter setting”

<b>SERIAL INIT</b> Not valid for Modbus communication	
<b>SERIAL PROTOCOL</b> Not valid for Modbus communication	
<b>SERIAL TIMER (S)</b> Not valid for Modbus communication	
<b>SERIAL VALUE</b> Not valid for Modbus communication	
<b>MODBUS</b> This parameter enables the Modbus protocol and determines the Modbus address.	
0	Do not use for Modbus protocol (Modbus disabled)
1 ... 247	Modbus enabled: Serial interface is using Modbus RTU protocol The number set here determines the Modbus node address.

**6.2.2. Modbus Communication**

The following Modbus functions are available:

**Read Holding Registers and Write Multiple Registers**

With the functions “Read Holding Registers” and “Write Multiple Registers” it is possible to access all registers of the device.

All variables (actual data) and status registers are mapped to Modbus Holding Registers. However, as all registers of the device are 32 bit registers but Modbus Holding registers are only 16 bit registers, each register of the device requires two Holding registers. (For this reason the use of Modbus function “Write Single Register” is not possible.)

It is only possible to access to one single register of the touchMATRIX® device by each read or write operation, therefore the “Quantity (or number) of registers” in the Modbus request must always be 2.

**Access to parameters**

Holding Register 0x0000 / 0x0001 hex and following allow access to the device parameters.

The holding register numbers for a certain parameter can be calculated by the parameter # that can be found in the parameter table in the touchMatrix® device manual:

Holding Register low = (parameter #) x 2

Holding Register high = (parameter #) x 2 + 1

Example:

Access to parameter # 51 "PRESELECTION 1" by Holding Register 0x0066 and 0x0067 hex.

**Access to actual data**

Holding Register 0x1000 / 0x1001 hex and following allow access to variables of the device (actual data registers):

- Holding Register 0x1000 / 0x1001 hex → Actual data with serial Code “:0” (Display value)
- Holding Register 0x1002 / 0x1003 hex → Actual data with serial Code “:1”
- Holding Register 0x1004 / 0x1005 hex → Actual data with serial Code “:2”
- Holding Register 0x1006 / 0x1007 hex → Actual data with serial Code “:3”
- etc.

**Access to status registers**

Holding Register 0x2000 / 0x2001 hex and following allow access to status registers of the device:

- Holding Register 0x2000 / 0x2001 hex → Output Status (Ctrl. Out status, read only)
- Holding Register 0x2002 / 0x2003 hex → Serial Commands
- Holding Register 0x2004 / 0x2005 hex → External Command (Ctrl. In status, read only)
- Holding Register 0x2006 / 0x2007 hex → All Commands (read only)

**Read Coils and Write Single Coil**

With the functions “Read Coils” and “Write Single Coil” it is possible to read and set/reset single commands:

Coil number	Serial code of command	Command	
0	54	Reset / Set	Reset/Set Value
1	55	Freeze Display	Freeze actual display value
2	56	Touch Disable	Disable touch screen
3	57	Clear Lock	Loosen locking of all outputs / relay
4	58	Clear Min/Max	Reset of the min. / max. values
5	59	Serial Print (do not use with Modbus)	Sending of serial data
6	60	Teach Preset 1	Current display value is stored as PRESELECTION 1
7	61	Teach Preset 2	Current display value is stored as PRESELECTION 2
8	62	Teach Preset 3	Current display value is stored as PRESELECTION 3
9	63	Teach Preset 4	Current display value is stored as PRESELECTION 4
10	64	Scroll Display	Display switching (see display in operation mode)
11	65	Clear Loop Time	Release all latched switching conditions
12	66	Start Preselection	The preselection starts

13	67	Activate Data (not required with Modbus)	The data is activated.
14	68	Store to EEPROM	Store to EEPROM
15	69	Testprogram (do not use with Modbus)	Testprogram (do not use with Modbus)

### 6.2.3. Diagnostics

The device supports the diagnostics subfunction 00 "Return Query Data". Other diagnostics functions are not available.

### 6.3. Parameter / serial codes

#	Menue	Name	Serial Code	Min	Max	Default
0	GENERAL MENU	OPERATIONAL MODE	0	0	4	0
1	GENERAL MENU	ENCODER PROPERTIES	1	0	3	0
2	GENERAL MENU	ENCODER SUPPLY	2	0	1	1
3	GENERAL MENU	COUNTING DIRECTION	3	0	1	0
4	GENERAL MENU	SCALE UNITS	4	0	28	0
5	GENERAL MENU	SCALE UNITS (BATCH)	5	0	28	16
6	GENERAL MENU	LINIARIZATION MODE	6	0	2	0
7	GENERAL MENU	PIN PRESELECTION	7	0	9999	0
8	GENERAL MENU	PIN PARAMETER	8	0	9999	0
9	GENERAL MENU	BACK UP MEMORY	9	0	1	1
10	GENERAL MENU	FACTORY SETTINGS	10	0	1	0
11	GENERAL MENU	-	11	0	0	0
12	MODE SPEED	DISPLAY VALUE	12	1	99999999	1000
13	MODE SPEED	BASE FREQUENCY (HZ)	13	1	500000	100
14	MODE SPEED	DECMIAL POINT	14	0	7	1
15	MODE SPEED	SAMPLING TIME (S)	15	5	9999	100
16	MODE SPEED	WAIT TIME (S)	16	1	8000	100
17	MODE SPEED	STANDSTILL TIME (S)	17	0	9999	0
18	MODE SPEED	AVERAGE FILTER	18	0	8	0
19	MODE SPEED	FOR/REV DETECTION	19	0	1	0
20	MODE SPEED	-	20	0	0	0
21	MODE SPEED	-	21	0	0	0
22	MODE PROCESS TIME	DISPLAY FORMAT	22	0	3	0
23	MODE PROCESS TIME	DISPLAY VALUE	23	1	99999999	1000
24	MODE PROCESS TIME	BASE FREQUENCY (HZ)	24	1	500000	100
25	MODE PROCESS TIME	SAMPLING TIME (S)	25	5	9999	100
26	MODE PROCESS TIME	WAIT TIME (S)	26	1	8000	100
27	MODE PROCESS TIME	STANDSTILL TIME (S)	27	0	9999	0
28	MODE PROCESS TIME	AVERAGE FILTER	28	0	8	0
29	MODE PROCESS TIME	-	29	0	0	0
30	MODE PROCESS TIME	-	30	0	0	0
31	MODE TIMER	TIME BASE	31	0	9	0
32	MODE TIMER	START / STOP	32	0	3	2
33	MODE TIMER	AUTO RESET	33	0	1	0
34	MODE TIMER	LATCH FUNCTION	34	0	1	0
35	MODE TIMER	SET VALUE	35	0	99999999	0
36	MODE TIMER	INC / DEC MODE	36	0	1	0
37	MODE TIMER	TOTAL TIME MODE	37	0	1	0
38	MODE TIMER	TOTAL TIME SET VALUE	38	0	99999999	0
39	MODE TIMER	-	39	0	0	0
40	MODE COUNTER	COUNT MODE	40	0	5	3
41	MODE COUNTER	FACTOR	41	1	9999999	100000

42	MODE COUNTER	SET VALUE	42	-99999999	99999999	0
43	MODE COUNTER	DECIMALPOINT	43	0	7	0
44	MODE COUNTER	BATCH / TOTAL MODE	44	0	4	0
45	MODE COUNTER	BATCH / TOTAL SET VALUE	45	0	99999999	0
46	MODE COUNTER	ROUND LOOP VALUE	46	0	99999999	0
47	MODE COUNTER	-	47	0	0	0
48	MODE COUNTER	-	48	0	0	0

49	MODE VELOCITY	START / STOP	A0	0	3	0
50	MODE VELOCITY	DISPLAY VALUE	A1	1	99999999	1000
51	MODE VELOCITY	BASE TIME (S)	A2	1	999999	1000
52	MODE VELOCITY	DECIMALPOINT	A3	0	7	0
53	MODE VELOCITY	WAIT TIME (S)	A4	0	9999	0
54	MODE VELOCITY	STANDSTILL TIME (S)	A5	0	9999	0
55	MODE VELOCITY	-	A6	0	0	0
56	MODE VELOCITY	-	A7	0	0	0
57	MODE VELOCITY	-	A8	0	0	0
58	PRESELECTION VALUES	PRESELECTION 1	A9	-99999999	99999999	1000
59	PRESELECTION VALUES	PRESELECTION 2	B0	-99999999	99999999	2000
60	PRESELECTION VALUES	PRESELECTION 3	B1	-99999999	99999999	3000
61	PRESELECTION VALUES	PRESELECTION 4	B2	-99999999	99999999	4000
62	PRESELECTION 1 MENU	SOURCE 1	B3	0	5	0
63	PRESELECTION 1 MENU	MODE 1	B4	0	11	0
64	PRESELECTION 1 MENU	HYSTERESIS 1	B5	0	99999	0
65	PRESELECTION 1 MENU	PULSE TIME 1 (S)	B6	0	60000	0
66	PRESELECTION 1 MENU	OUTPUT TARGET 1	B7	0	6	1
67	PRESELECTION 1 MENU	OUTPUT POLARITY 1	B8	0	1	0
68	PRESELECTION 1 MENU	OUTPUT LOCK 1	B9	0	1	0
69	PRESELECTION 1 MENU	START UP DELAY 1 (S)	C0	0	60000	0
70	PRESELECTION 1 MENU	EVENT COLOR 1	C1	0	3	0
71	PRESELECTION 1 MENU	-	C2	0	0	0
72	PRESELECTION 2 MENU	SOURCE 2	C3	0	5	0
73	PRESELECTION 2 MENU	MODE 2	C4	0	11	0
74	PRESELECTION 2 MENU	HYSTERESIS 2	C5	0	99999	0
75	PRESELECTION 2 MENU	PULSE TIME 2 (S)	C6	0	60000	0
76	PRESELECTION 2 MENU	OUTPUT TARGET 2	C7	0	6	2
77	PRESELECTION 2 MENU	OUTPUT POLARITY 2	C8	0	1	0
78	PRESELECTION 2 MENU	OUTPUT LOCK 2	C9	0	1	0
79	PRESELECTION 2 MENU	START UP DELAY 2 (S)	D0	0	60000	0
80	PRESELECTION 2 MENU	EVENT COLOR 2	D1	0	3	0
81	PRESELECTION 2 MENU	-	D2	0	0	0
82	PRESELECTION 3 MENU	SOURCE 3	D3	0	5	0
83	PRESELECTION 3 MENU	MODE 3	D4	0	11	0
84	PRESELECTION 3 MENU	HYSTERESIS 3	D5	0	99999	0
85	PRESELECTION 3 MENU	PULSE TIME 3 (S)	D6	0	60000	0
86	PRESELECTION 3 MENU	OUTPUT TARGET 3	D7	0	6	3
87	PRESELECTION 3 MENU	OUTPUT POLARITY 3	D8	0	1	0
88	PRESELECTION 3 MENU	OUTPUT LOCK 3	D9	0	1	0
89	PRESELECTION 3 MENU	START UP DELAY 3	E0	0	1	0
90	PRESELECTION 3 MENU	EVENT COLOR 3	E1	0	3	0
91	PRESELECTION 3 MENU	-	E2	0	0	0

92	PRESELECTION 4 MENU	SOURCE 4	E3	0	5	0
93	PRESELECTION 4 MENU	MODE 4	E4	0	11	0
94	PRESELECTION 4 MENU	HYSTERESIS 4	E5	0	99999	0
95	PRESELECTION 4 MENU	PULSE TIME 4 (S)	E6	0	60000	0
96	PRESELECTION 4 MENU	OUTPUT TARGET 4	E7	0	6	4
97	PRESELECTION 4 MENU	OUTPUT POLARITY 4	E8	0	1	0

98	PRESELECTION 4 MENU	OUTPUT LOCK 4	E9	0	1	0
99	PRESELECTION 4 MENU	START UP DELAY 4	F0	0	1	0
100	PRESELECTION 4 MENU	EVENT COLOR 4	F1	0	3	0
101	PRESELECTION 4 MENU	-	F2	0	0	0
102	SERIAL MENU	UNIT NUMBER	90	11	99	11
103	SERIAL MENU	SERIAL BAUD RATE	91	0	2	0
104	SERIAL MENU	SERIAL FORMAT	92	0	9	0
105	SERIAL MENU	SERIAL INIT	9~	0	1	0
106	SERIAL MENU	SERIAL PROTOCOL	F3	0	1	0
107	SERIAL MENU	SERIAL TIMER (S)	F4	0	60000	0
108	SERIAL MENU	SERIAL VALUE	F5	0	9	0
109	SERIAL MENU	MODBUS	F6	0	247	0
110	SERIAL MENU	-	F7	0	0	0
111	SERIAL MENU	-	F8	0	0	0
112	ANALOG MENU	ANALOG SOURCE	F9	0	5	0
113	ANALOG MENU	ANALOG FORMAT	G0	0	2	0
114	ANALOG MENU	ANALOG START	G1	-99999999	99999999	0
115	ANALOG MENU	ANALOG END	G2	-99999999	99999999	10000
116	ANALOG MENU	ANALOG GAIN %	G3	0	11000	10000
117	ANALOG MENU	ANALOG OFFSET %	G4	-9999	9999	0
118	ANALOG MENU	-	G5	0	0	0
119	COMMAND MENU	INPUT 1 ACTION	G6	0	29	0
120	COMMAND MENU	INPUT 1 CONFIG.	G7	0	3	2
121	COMMAND MENU	INPUT 2 ACTION	G8	0	29	0
122	COMMAND MENU	INPUT 2 CONFIG.	G9	0	3	2
123	COMMAND MENU	INPUT 3 ACTION	H0	0	29	0
124	COMMAND MENU	INPUT 3 CONFIG.	H1	0	3	2
125	COMMAND MENU	-	H2	0	0	0
126	COMMAND MENU	-	H3	0	0	0
127	COMMAND MENU	-	H4	0	0	0
128	COMMAND MENU	-	H5	0	0	0
129	COMMAND MENU	-	H6	0	0	0
130	DISPLAY MENU	SOURCE DUAL TOP	H7	0	5	1
131	DISPLAY MENU	SOURCE DUAL DOWN	H8	0	5	2
132	DISPLAY MENU	COLOR	H9	0	2	0
133	DISPLAY MENU	BRIGHTNESS %	I0	10	100	90
134	DISPLAY MENU	CONTRAST	I1	0	2	1
135	DISPLAY MENU	SCREEN SAVER (S)	I2	0	9999	0
136	DISPLAY MENU	UP-DATE-TIME (S)	I3	5	9999	100
137	DISPLAY MENU	FONT	I4	0	1	0
138	DISPLAY MENU	START DISPLAY	I5	0	6	0
139	DISPLAY MENU	LARGE DISPLAY	I6	0	5	0
140	LINEARIZATION MENU	P1(X)	I7	-99999999	99999999	0
141	LINEARIZATION MENU	P1(Y)	I8	-99999999	99999999	0

142	LINEARIZATION MENU	P2(X)	I9	-99999999	99999999	0
143	LINEARIZATION MENU	P2(Y)	J0	-99999999	99999999	0
144	LINEARIZATION MENU	P3(X)	J1	-99999999	99999999	0
145	LINEARIZATION MENU	P3(Y)	J2	-99999999	99999999	0
146	LINEARIZATION MENU	P4(X)	J3	-99999999	99999999	0



#	Menue	Name	Serial Code	Value	Min	Max	Default
147	LINEARIZATION MENU	P4(Y)	J4	0	-99999999	99999999	0
148	LINEARIZATION MENU	P5(X)	J5	0	-99999999	99999999	0
149	LINEARIZATION MENU	P5(Y)	J6	0	-99999999	99999999	0
150	LINEARIZATION MENU	P6(X)	J7	0	-99999999	99999999	0
151	LINEARIZATION MENU	P6(Y)	J8	0	-99999999	99999999	0
152	LINEARIZATION MENU	P7(X)	J9	0	-99999999	99999999	0
153	LINEARIZATION MENU	P7(Y)	K0	0	-99999999	99999999	0
154	LINEARIZATION MENU	P8(X)	K1	0	-99999999	99999999	0
155	LINEARIZATION MENU	P8(Y)	K2	0	-99999999	99999999	0
156	LINEARIZATION MENU	P9(X)	K3	0	-99999999	99999999	0
157	LINEARIZATION MENU	P9(Y)	K4	0	-99999999	99999999	0
158	LINEARIZATION MENU	P10(X)	K5	0	-99999999	99999999	0
159	LINEARIZATION MENU	P10(Y)	K6	0	-99999999	99999999	0
160	LINEARIZATION MENU	P11(X)	K7	0	-99999999	99999999	0
161	LINEARIZATION MENU	P11(Y)	K8	0	-99999999	99999999	0
162	LINEARIZATION MENU	P12(X)	K9	0	-99999999	99999999	0
163	LINEARIZATION MENU	P12(Y)	L0	0	-99999999	99999999	0
164	LINEARIZATION MENU	P13(X)	L1	0	-99999999	99999999	0
165	LINEARIZATION MENU	P13(Y)	L2	0	-99999999	99999999	0
166	LINEARIZATION MENU	P14(X)	L3	0	-99999999	99999999	0
167	LINEARIZATION MENU	P14(Y)	L4	0	-99999999	99999999	0
168	LINEARIZATION MENU	P15(X)	L5	0	-99999999	99999999	0
169	LINEARIZATION MENU	P15(Y)	L6	0	-99999999	99999999	0
170	LINEARIZATION MENU	P16(X)	L7	0	-99999999	99999999	0
171	LINEARIZATION MENU	P16(Y)	L8	0	-99999999	99999999	0
172	LINEARIZATION MENU	P17(X)	L9	0	-99999999	99999999	0
173	LINEARIZATION MENU	P17(Y)	M0	0	-99999999	99999999	0
174	LINEARIZATION MENU	P18(X)	M1	0	-99999999	99999999	0
175	LINEARIZATION MENU	P18(Y)	M2	0	-99999999	99999999	0
176	LINEARIZATION MENU	P19(X)	M3	0	-99999999	99999999	0
177	LINEARIZATION MENU	P19(Y)	M4	0	-99999999	99999999	0
178	LINEARIZATION MENU	P20(X)	M5	0	-99999999	99999999	0
179	LINEARIZATION MENU	P20(Y)	M6	0	-99999999	99999999	0
180	LINEARIZATION MENU	P21(X)	M7	0	-99999999	99999999	0
181	LINEARIZATION MENU	P21(Y)	M8	0	-99999999	99999999	0
182	LINEARIZATION MENU	P22(X)	M9	0	-99999999	99999999	0
183	LINEARIZATION MENU	P22(Y)	N0	0	-99999999	99999999	0
184	LINEARIZATION MENU	P23(X)	N1	0	-99999999	99999999	0
185	LINEARIZATION MENU	P23(Y)	N2	0	-99999999	99999999	0
186	LINEARIZATION MENU	P24(X)	N3	0	-99999999	99999999	0
187	LINEARIZATION MENU	P24(Y)	N4	0	-99999999	99999999	0

## Serial codes of commands:

Serial code	Command
54	RESET/SET
55	FREEZE DISPLAY
56	TOUCH DISABLE
57	CLR LOCK
58	CLR MIN MAX
59	SERIAL PRINT
60	TEACH PRES 1
61	TEACH PRES 2
62	TEACH PRES 3
63	TEACH PRES 4
64	SCROLL_DISPLAY
65	CLEAR LOOP TIME
66	START PRESELECTION
67	ACTIVATE DATA
68	STORE EEPROM
69	TESTPROGRAMM

## 6.4. Linearization

The linearization function of this unit allows converting a linear input signal into a non-linear developing (or vice versa). There are 24 programmable x/y coordinates available, which can be set in any desired distance over the full conversion range. Between two coordinates, the unit uses linear interpolation. Therefore it is advisable to use more coordinates in a range with strong curves and only a few coordinates where the curvature is less.

To specify an individual linearization curve, the parameter LINEARISAZATION MODE must be set to either 1 QUADRANT or 4 QUADRANT (see following diagram).

The parameters P1(X) to P24(X) are used to specify the coordinates on the x-axis. These are the measuring values that the unit normally would generate according to the actual input signal.

Now enter the attached values to parameter P1(Y) to P24(Y). These are the values that the unit will generate instead of the x- values, i.e. P5(Y) replaces P5(X) etc.

**The X-Coordinates must use continuously increasing settings, i.e. P1(X) must have the lowest and P24(X) must have the highest setting. If the measured value is bigger than the last defined X-value, the corresponding Y-value is displayed.**

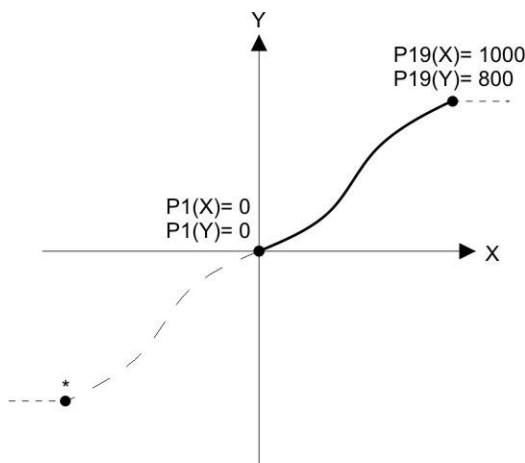

Example: Linearization Mode: 1 Quadrant

\* Linearization is point symmetric to 1. Quadrant

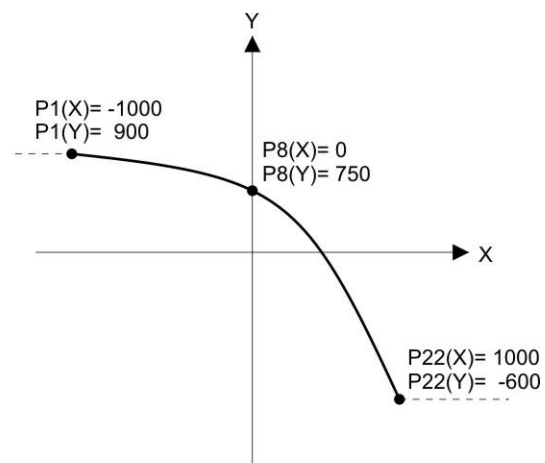

Example: Linearization Mode: 4 Quadrant

### Mode: 1 Quadrant:

**P1(X) must be set to zero. Linearization is only defined in the positive range and the negative range will be mirrored symmetric to central point.**

### Mode: 4 Quadrant:

**P1(X) can also be set to a negative value. If the measured value is smaller than P1(X), P1(Y) is displayed.**

Application Example:

The picture below shows a watergate where the opening is picked up by means of an incremental encoder. We would like to display the clearance of the gate "d", but the existing encoder information is proportional to the angular information  $\phi$ .

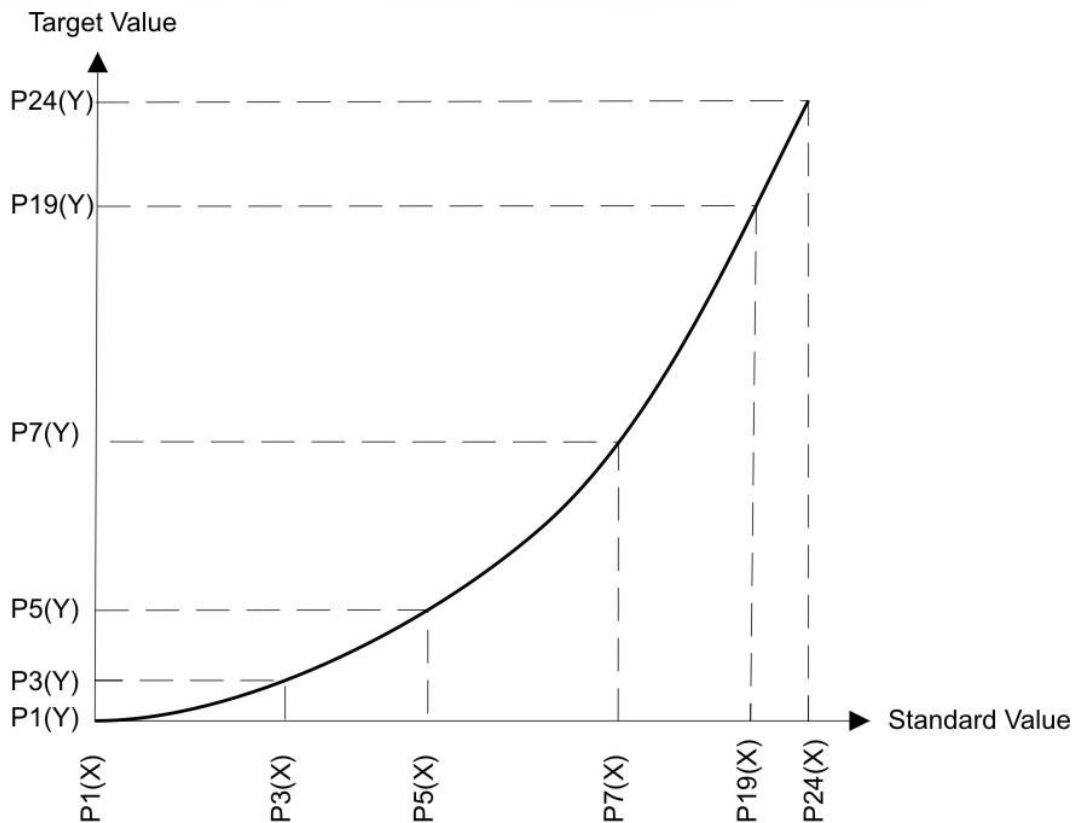
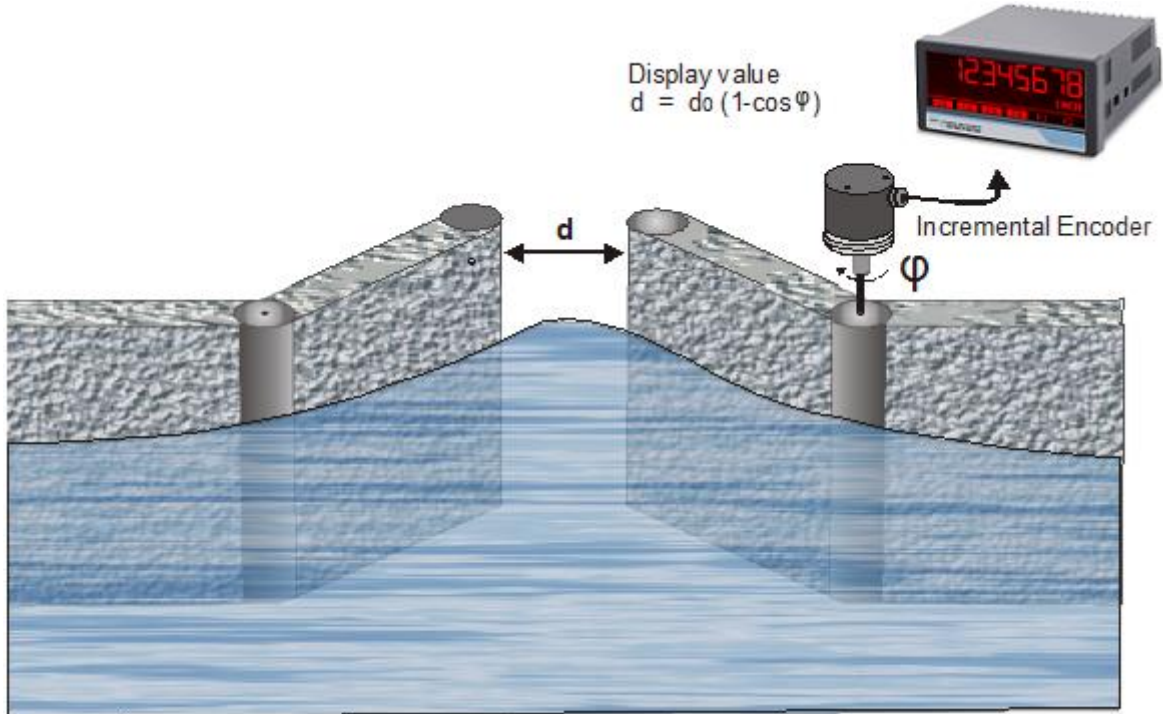

## 6.5. Dimensions

front view

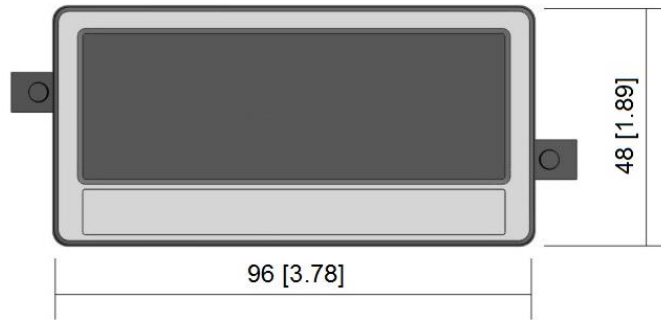

rear view

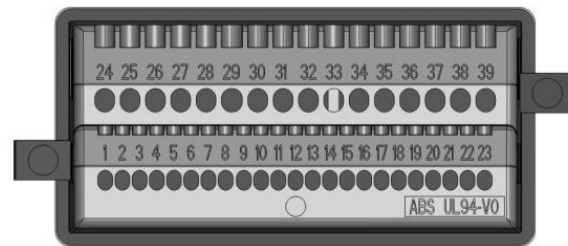

side view

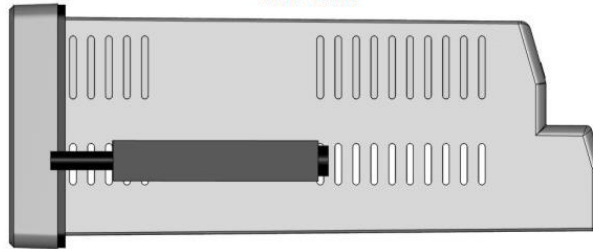

topview

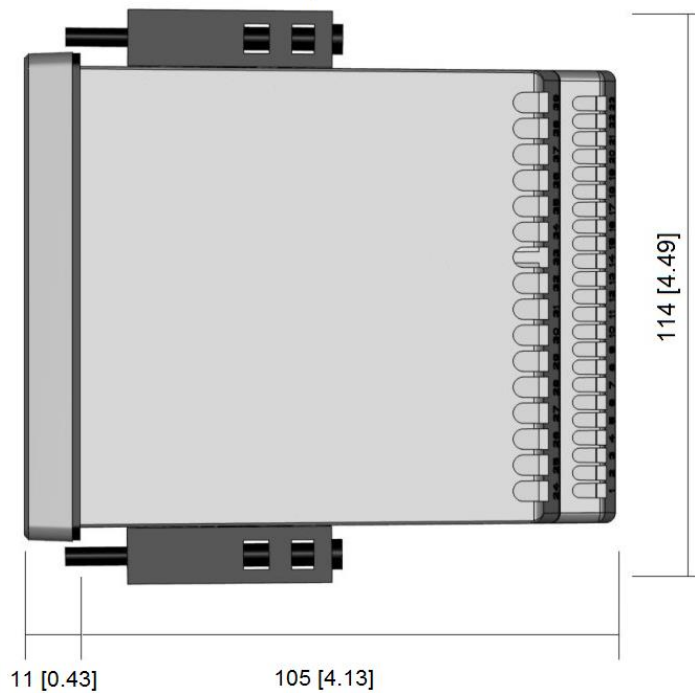

## 6.6. Technical specifications

Technical Specifications:		
<b>Connections:</b>	Connector type:	screw terminal, 1.5 mm <sup>2</sup> / AWG 16
<b>Power supply (DC):</b>	Input voltage:	18 ... 30 VDC
	Protection circuit:	reverse polarity protection
	Consumption:	approx. 100 mA (unloaded)
	Fuse protection:	extern: T 0.5 A
<b>Encoder supply:</b>	DC version:	24 VDC (approx. 1 V lower than the power supply voltage), max. 250 mA
<b>Incremental inputs:</b>	Number of inputs:	2 (A, B)
	Configuration:	PNP, NPN, Namur or Tri-State
	Format:	HTL (Low 0 ... 3 V, High 9 ... 30 V)
	Frequency:	max. 250 kHz
	Load:	max. 6 mA / Ri > 5 kOhm / 470 pF
<b>Accuracy:</b>	Measurement:	+/- 50 ppm, +/- 1 digit
<b>Control inputs:</b>	Number of inputs:	3
	Format:	HTL, PNP (Low 0 ... 3 V, High 9 ... 30 V)
	Frequency:	max. 10 kHz
	Load:	max. 2 mA / Ri > 15 kOhm / 470 pF
<b>Analog output:</b>	Configuration:	current or voltage operation
	Voltage output:	-10...+10 V (max. 2 mA)
	Current output:	0/4 ... 20 mA (burden: max. 270 Ohm)
	Resolution:	16 Bit
	Accuracy:	± 0,1 % (0 ... +45°C), ± 0,15 % (-20 ... 0 / +45 ... +60°C)
	Reaction time:	< 150 ms
<b>Control outputs:</b>	Number of outputs:	4
	Format / level:	5 ... 30 V (depend on COM+ voltage), PNPc
	Output current:	max. 200 mA
	Reaction time:	< 1 ms

<b>Serial interface:</b>	Format:	RS232
	Baudrate:	9600, 19200 oder 38400 Baud
<b>Display:</b>	Type:	Graphic LCD with backlight
	Display range:	8 digits plus sign (-99999999 ... 99999999)
	Digit height	13 mm height
	Color:	red / green / yellow (selectable)
	Operation:	resistive touchscreen
<b>Housing:</b>	Material:	ABS, UL 94 V-0
	Mounting:	panel
	Dimensions (w x h x d):	96 x 48 x 116 mm / 3.78 x 1.89 x 4.56 inch
	Cut out (w x h):	91 x 43 mm / 3.58 x 1.69 inch
	Protection class:	IP65 (front), IP20 (rear)
	Weight:	approx. 200 g
<b>Ambient temperature:</b>	Operation:	-20°C ... +60°C / -4 ... 140°F
	Storage:	-25°C ... +70°C / -13 ... 158°F
<b>Conformity and standards:</b>	EMC 2014/30/EU:	EN 61000-6-2, EN 61000-6-3, EN 61000-6-4, EN 61326-1

	RoHS ( II ) 2011/65/EU RoHS ( III ) 2015/863:	EN IEC 63000
--	--	--------------